

Doc. A/74
18 June 2004

ATSC Recommended Practice: Receiver Performance Guidelines

Advanced Television Systems Committee

1750 K Street, N.W.

Suite 1200

Washington, D.C. 20006

www.atsc.org

The Advanced Television Systems Committee, Inc., is an international, non-profit organization developing voluntary standards for digital television. The ATSC member organizations represent the broadcast, broadcast equipment, motion picture, consumer electronics, computer, cable, satellite, and semiconductor industries. Specifically, ATSC is working to coordinate television standards among different communications media focusing on digital television, interactive systems, and broadband multimedia communications. ATSC is also developing digital television implementation strategies and presenting educational seminars on the ATSC standards.

ATSC was formed in 1982 by the member organizations of the Joint Committee on InterSociety Coordination (JCIC): the Electronic Industries Association (EIA), the Institute of Electrical and Electronic Engineers (IEEE), the National Association of Broadcasters (NAB), the National Cable and Telecommunications Association (NCTA), and the Society of Motion Picture and Television Engineers (SMPTE). Currently, there are approximately 140 members representing the broadcast, broadcast equipment, motion picture, consumer electronics, computer, cable, satellite, and semiconductor industries.

ATSC Digital TV Standards include digital high definition television (HDTV), standard definition television (SDTV), data broadcasting, multichannel surround-sound audio, and satellite direct-to-home broadcasting.

Table of Contents

1. SCOPE AND DOCUMENT STRUCTURE	8
1.1 Foreword	8
1.2 Scope	8
1.3 Document Structure	8
2. INFORMATIVE REFERENCES	9
3. SYSTEM OVERVIEW	9
3.1 Objective	9
3.2 System Block Diagrams	9
4. RECEIVER PERFORMANCE GUIDELINES	11
4.1 Sensitivity	11
4.2 Multi-Signal Overload	11
4.3 Phase Noise	12
4.4 Selectivity	12
4.4.1 Co-Channel Rejection	12
4.4.2 First Adjacent Channel Rejection	13
4.4.3 Taboo Channel Rejection	13
4.4.3.1 DTV Interference into DTV	14
4.4.3.2 NTSC Interference into DTV	14
4.4.4 Burst Noise Performance	14
4.5 Multipath	15
4.5.1 Introduction	15
4.5.2 Field Ensembles	15
4.5.2.1 Capture Location	15
4.5.2.2 List of Recommended Field Ensembles	15
4.5.2.3 Field Ensemble Characterization	16
4.5.2.4 Data Format	17
4.5.2.5 Recommended Physical Support for Field Ensemble Data Transfer	17
4.5.3 Laboratory Ensembles	18
4.5.3.1 Channel Impulse Response Range	18
4.5.3.1.1 Typical Echo Range	18
4.5.3.1.2 Single Static Echoes Amplitude / Equalizer Profile	18
4.5.3.2 Single Dynamic Echoes	20
4.5.3.3 Multiple Dynamic Echo Ensembles	21
4.5.3.4 Dynamic Multipath in the Presence of Doppler Frequency Shift and Airplane Flutter	23
4.6 Antenna Interface	23
4.7 Consumer Interface—Received Signal Quality Indicator	24

ANNEX A: CAPTURE LABELS AND DESCRIPTIONS	25
ANNEX B: IMPULSE RESPONSE ANALYSIS	36
1. SCOPE.....	36
2. CHANNEL IMPULSE RESPONSE ANALYSIS	36
2.1 Data Analysis Using Real Versus Complex Demodulators/Equalizers	36
2.2 Channel Estimations Using 511 Pseudo-Random Sequence	36
2.3 Frequency Doppler Estimate	39
2.3.1 Comments on Doppler Analysis	39
2.3.2 Methodology for Doppler Frequency Estimate	40
3. ANALYSIS OF RF CAPTURED DTV SIGNAL.....	41
3.1 Captured Channel WAS-105/51/01	41
3.2 Captured Channel WAS-032/39/01¹ (Indoor)	44
3.3 Captured Channel WAS-049/36/01¹	47
3.4 Captured Channel WAS-034/48/01	55
3.5 Captured Channel WAS-311/48/01	57
3.6 Captured Channel WAS-114/27/01¹	60
3.7 Captured Channel WAS-101/39/01¹	61
3.8 Captured Channel NYC-216/56/01	62
3.9 Captured Channel NYC-217/56/01	63
ANNEX C: EXAMPLE OF CHANNEL IMPULSE RESPONSE WITH LONG PRE AND POST-ECHO ...	64
1. SCOPE.....	64
1.1 Far Pre-Echo	64
1.2 Far Post-Echo	65
ANNEX D: ANALYSIS OF RECEIVED POWER FOR A SAMPLE RECEIVER	66

Index of Tables and Figures

Table 4.1 Co-Channel Rejection Thresholds	12
Table 4.2 First Adjacent Channel Thresholds	13
Table 4.3 Taboo Channel Rejection Thresholds for DTV Interference into DTV	14
Table 4.4 Taboo Channel Rejection Thresholds for NTSC Interference into DTV	14
Table 4.5 Field Ensemble Description	16
Table 4.6 ATSC Test Group R.1. Multiple Dynamic Echoes	20
Table 4.7 ATSC R.1 Ensembles	20
Table 4.8 ATSC Test Group R.2. Multiple Static and Dynamic Echoes	21
Table 4.9 ATSC R2.1 Ensembles	22
Table 4.10 ATSC R2.2 Ensembles	22
Table D.1 TV/DTV Received Power Analysis; Location: Hollywood, Fla.	67
Figure 3.1 Overall block diagram of the digital terrestrial television broadcasting model.	10
Figure 3.2 Digital television receiver front-end subsystem block diagram.	11
Figure 4.3 Recommended target performance for a desired DTV signal in the presence of a single static echo of varying delay.	19
Figure A.1 RF capture spreadsheet. (<i>Note:</i> an electronic version of this Microsoft Excel document is available from ATSC.)	26
Figure B.1 Method of channel estimation using the PN511 pseudo-random number sequence in the 8-VSB field sync involves a cross correlation with three ideal PN511 sequences.	37
Figure B.2 Cross-correlation of an ideal 8-VSB PN511 sequence showing a single main path at zero microseconds.	37
Figure B.3 Channel estimation of an 8-VSB signal capture in the laboratory in the presence of a 10 μ s echo that is 6 dB lower in power than the main path.	38
Figure B.4 Power compensation function required to obtain the actual echo power from channel estimations using the 8-VSB PN511 sequence.	39
Figure B.5 Peak echo power as a function of echo delay observed for the duration of the RF capture at site WAS-105/51/01.	41
Figure B.6 Power of the main path in addition to the greatest “echoes” shows considerable variation over the duration of the RF capture for site WAS-105/51/01.	42
Figure B.7 Total power of the main path and ± 3 “echoes” about the main path illustrating the power is constant even though the main path is dynamic.	43
Figure B.8 Peak echo power as a function of echo delay observed for the duration of the RF capture at indoor site WAS-32/39/01.	44

- Figure B.9** The 11 μ s echo magnitude at the beginning of the capture at indoor site WAS-32/39/01. Doppler frequency is 75 Hz. 45
- Figure B.10** The 11 μ s echo magnitude 6.9 seconds into the capture at indoor site WAS-32/39/01. Doppler frequency is 17 Hz. 46
- Figure B.11** Peak echo power as a function of echo delay observed for the duration of the RF capture at indoor site WAS-49/36/01. The evenly spaced echoes peaked at $\pm 1.67 \mu$ s indicate that the main path and the echo alternate—a “bobbing” channel. 47
- Figure B.12** Echo Magnitude for the 1.75 μ s echo relative to the main path at the beginning of the capture at indoor site WAS-49/36/01. The echo magnitude is -15 dB relative to the main path. The Doppler frequency is 40 Hz. 48
- Figure B.13** Echo magnitude for the 1.75 μ s echo relative to the main path 3 seconds into the capture at indoor site WAS-49/36/01. The echo magnitude is -5 dB relative to the main path and has a Doppler frequency of 17 Hz. 49
- Figure B.14** Echo magnitude for the 1.75 μ s echo relative to the main path 7.5 seconds into the capture at indoor site WAS-49/36/01. The echo magnitude is -25 dB to -15 dB relative to the main path and has a Doppler frequency of 80Hz. 50
- Figure B.15** Echo Magnitude for the 1.75 μ s echo relative to the main path 9.2 seconds into the capture at indoor site WAS-49/36/01. The echo magnitude is -25 dB to -20 dB relative to the main path and has a Doppler frequency of 150 Hz. 51
- Figure B.16** Channel estimate (absolute value) for the RF capture at indoor site WAS-49/36/01 showing the main path and 1.75 μ s echo. 52
- Figure B.17** Channel estimate (absolute value) for the RF capture at indoor site WAS-49/36/01 showing the main path and 1.75 μ s echo. The 1.75 μ s echo has increased in magnitude with respect to the main path. 53
- Figure B.18** Channel estimate (absolute value) for the RF capture at indoor site WAS-49/36/01 showing the main path and 1.75 μ s echo. The 1.75 μ s echo is now a post echo with respect to the main path. 54
- Figure B.19** Peak echo power as a function of echo delay observed for the duration of the RF capture at indoor site WAS-034/48/01. 55
- Figure B.20** Power of the main path and three main echoes illustrates the dynamic nature of echoes for indoor site WAS-034/48/01. 56
- Figure B.21** Peak echo power as a function of echo delay observed for the duration of the RF capture at outdoor site WAS-311/48/01. The evenly spaced close-in echoes peaked at ± 372 ns indicate that the main path and the echo alternate—a “bobbing” channel. 57
- Figure B.22** Echo power as a function of echo delay observed at 22.906 seconds into the RF capture of outdoor site WAS-311/48/01. A strong pre-echo is present at -372 ns. 58
- Figure B.23** Echo power as a function of echo delay observed at 22.955 seconds into the RF capture of outdoor site WAS-311/48/01. After two additional field syncs in time, the 372 ns pre-echo is now the dominant path. 59

Figure B.24 Peak echo power observed in RF capture WAS/114/27/01	60
Figure B.25 Peak echo power observed in RF capture WAS/101/39/01	61
Figure B.26 Peak echo power observed in RF capture NYC/216/56/01 using a loop-type antenna in a fourth-floor urban apartment.	62
Figure B.27 Peak echo power observed in RF capture NYC/217/56/01 using a single bowtie-type antenna in a fourth-floor urban apartment.	63
Figure C.1 Channel impulse response with pre echo at $-14 \mu\text{s}$	64
Figure C.2 Channel impulse response with post echo at $57 \mu\text{s}$	65
Figure D.1 Power level at specified receiver.	66

ATSC Recommended Practice: Receiver Performance Guidelines

1. SCOPE AND DOCUMENT STRUCTURE

1.1 Foreword

This document addresses the front-end portion of a receiver of digital terrestrial television broadcasts. The recommended performance guidelines enumerated in this document are intended to assure that reliable reception will be achieved. Guidelines for interference rejection are based on the FCC planning factors that were used to analyze coverage and interference for the initial DTV channel allotments. Guidelines for sensitivity and multipath handling reflect field experience accumulated by testing undertaken by ATTC, MSTV, NAB, and receiver manufacturers.

1.2 Scope

This document provides recommended performance guidelines for the portion of a DTV receiver known as the “front-end,” which includes all circuitry from the antenna through the process of Forward Error Correction (FEC) that is associated with recovery and demodulation of the 8-VSB signal. The output of the receiver front-end is the input to the Transport Layer decoder. Specifically, the circuits whose performance contributes to meeting these guidelines are:

- Antenna and antenna control interface (CEA-909)
- Tuner, including radio frequency (RF) amplifier(s), associated filtering, and the local oscillator (or pair of local oscillators in the case of double conversion tuners) and mixer(s) required to bring the incoming RF channel frequency down to that of the intermediate frequency (IF) amplifier/filter.
- Intermediate Frequency (IF) amplification (with automatic gain control) and filtering, including the major portion of pre-decoding gain, channel selectivity, and at least a portion of the desired-channel band-shaping.
- Digital demodulation, including in-band interference rejection, multipath cancellation, and signal recovery.
- Forward Error Correction (FEC), wherein errors in the demodulated digital stream caused by transmission impairments are detected and corrected for incoming signals with signal-to-impairment ratios above a threshold. Packets with uncorrectable errors are “flagged” for possible mitigation in the video and audio decoders.

This document will not discuss optional means by which receivers might attempt to conceal or otherwise mitigate the visible or audible consequences of uncorrected bit stream errors. Although most receivers include circuits that effect some degree of error concealment, the results are subjective and not quantified so easily as the performance of the circuits listed above.

1.3 Document Structure

The recommended performance guidelines for a DTV receiver front-end described in this document include a general system overview, a list of reference documents, and the

recommended performance guidelines for the front-end circuit elements. The performance guidelines are divided into four general categories:

- Sensitivity
- Selectivity
- Interference rejection
- Multipath handling

2. INFORMATIVE REFERENCES

- [1] 47 CFR Part 73, *FCC Rules*.
- [2] ATSC A/52A, *Digital Audio Compression (AC-3) Standard*, Advanced Television Systems Committee, Washington, D.C., 20 August 2001.
- [3] ATSC A/53C, *ATSC Digital Television Standard*, Advanced Television Systems Committee, Washington, D.C., 21 May 2004.
- [4] ATSC A/65B, *Program and System Information Protocol for Terrestrial Broadcast and Cable*, Advanced Television Systems Committee, Washington, D.C., 18 March 2003.
- [5] ATSC A/69, *Program and System Information Protocol Implementations Performance guidelines for Broadcasters*, Advanced Television Systems Committee, Washington, D.C., 25 June 2002.
- [6] CEA-CEB-5, *Recommended Practice for DTV Receivers*.
- [7] CEA-909, *Antenna Control Interface*.

3. SYSTEM OVERVIEW

3.1 Objective

The performance guidelines for digital television broadcast receivers describe a system designed to ensure reliable reception of digital television in the terrestrial environment.

3.2 System Block Diagrams

A basic block diagram representation of the digital terrestrial television broadcast system is shown in Figure 3.1. The video subsystem, the service multiplex and transport, and the RF/transmission system are described in the ATSC A/53C Standard [3].

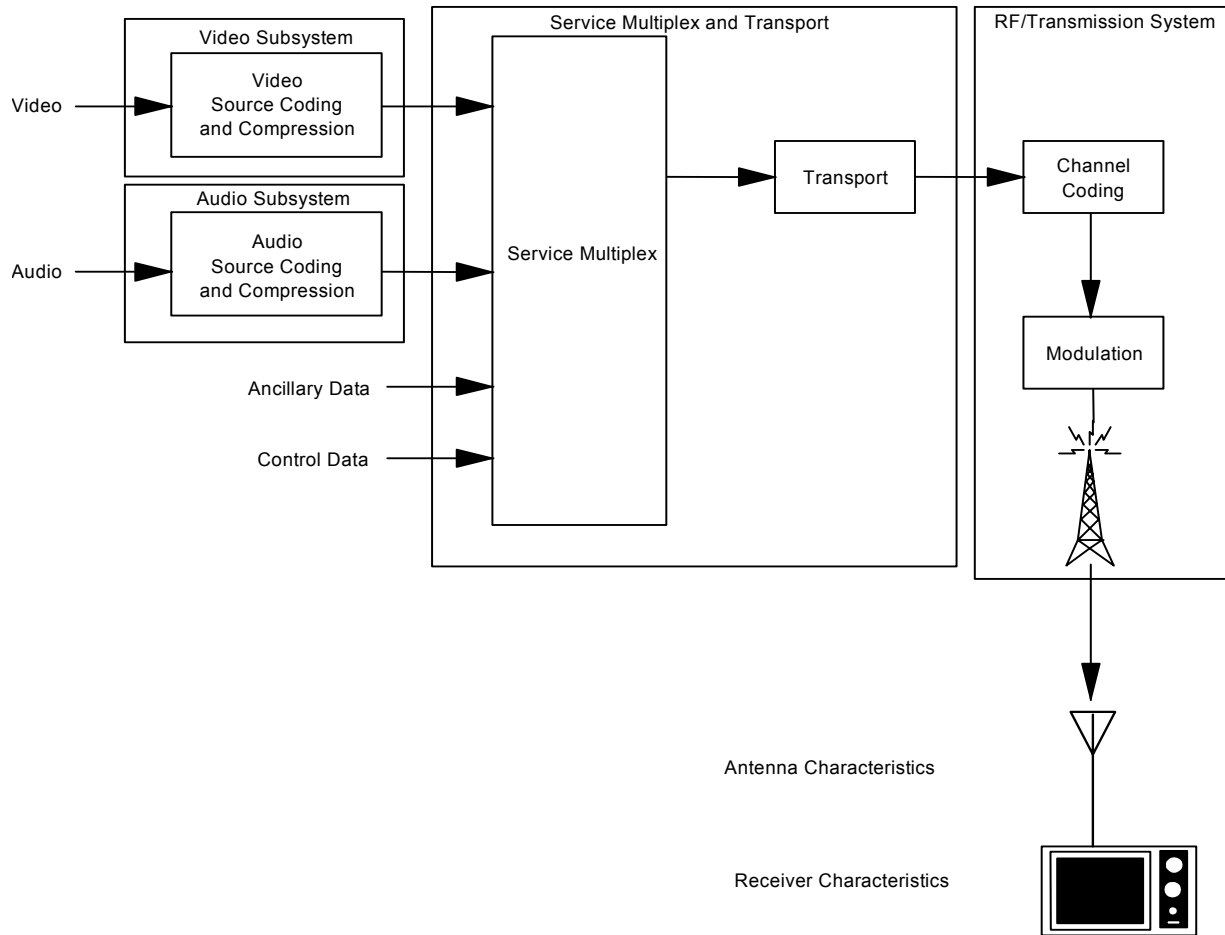

Figure 3.1 Overall block diagram of the digital terrestrial television broadcasting model.

Figure 3.2 shows a block diagram of the front-end sub-system of a DTV receiver.

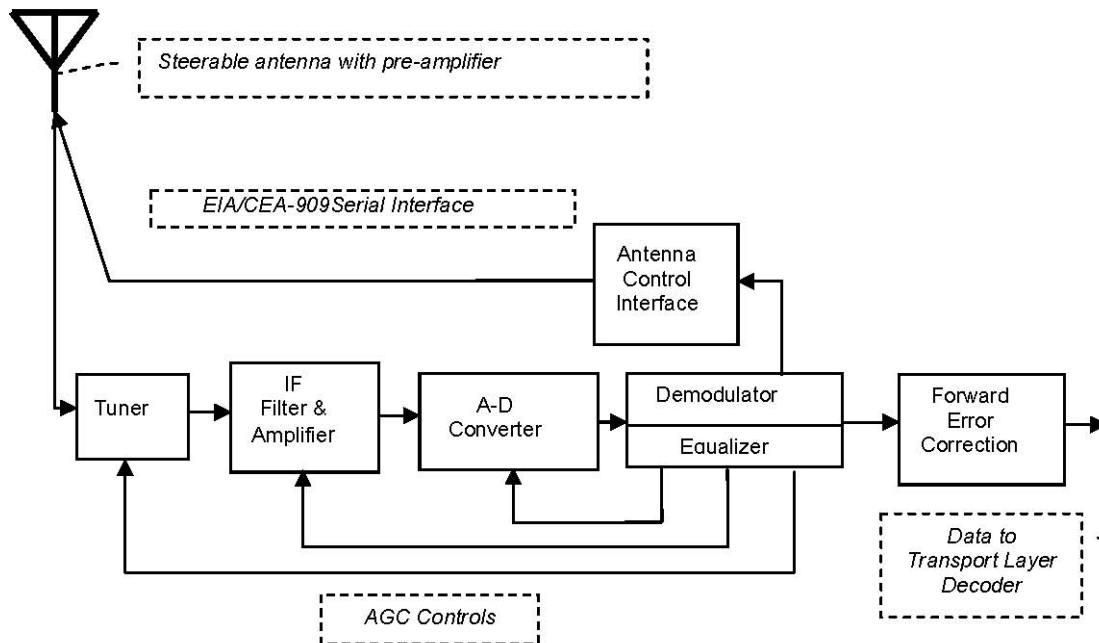

Figure 3.2 Digital television receiver front-end subsystem block diagram.

4. RECEIVER PERFORMANCE GUIDELINES

4.1 Sensitivity

A DTV receiver should achieve a bit error rate in the transport stream of no worse than 3×10^{-6} (i.e., the FCC Advisory Committee on Advanced Television Service (ACATS) Threshold of Visibility (TOV)) for input RF signal levels directly to the tuner from -83 dBm to -8 dBm for both the VHF and UHF bands. This relationship applies to a single DTV signal with no noise and no multipath interference. This is an overall receiver guideline and is meant to include all receiver circuit effects, including any phase noise that is contributed by the tuner in that particular receiver. It is desirable to expand the dynamic range beyond these bounds when possible.

4.2 Multi-Signal Overload

The DTV receiver should accommodate more than one undesired, high-level, NSTC or DTV signal at its input, received from transmission facilities that are in close proximity to one another. For purposes of this guideline it should be assumed that multiple signals, each approaching -8 dBm, will exist at the input of the receiver. Such signals may be derived from either a high gain antenna used in a close-in reception environment or via a mast mount amplifier/antenna combination, as utilized in a more distant environment.¹ Because the mix of signal levels will vary by market, no attempt to provide specific channel testing guidance has

¹ An examination of typical mast-mount amplifiers and preamplifiers, available in the fall of 2003, indicated that the capability to handle multiple signals is limited to approximately -8 dBm output before intermodulation products are internally generated.

been incorporated in this document. Rather, the receiver designer is directed to examples of channel allocation situations as illustrated in Annex D.²

4.3 Phase Noise

A DTV receiver should be able to tolerate phase noise levels at TOV of -80 dBc/Hz at a 20 kHz offset from the received signal source. This is not a measurement of the phase noise that exists internal to the receiver, but rather a measure of the receiver's ability to tolerate phase noise that has been introduced into the transmitted signal, for example, as a result of the signal passing through a translator with poor phase noise performance.

4.4 Selectivity

The values for adjacent channel and taboo channel rejection were developed based on available UHF data. With current technology, VHF performance is expected to exceed the UHF performance.

4.4.1 Co-Channel Rejection

The receiver should not exceed the following thresholds for rejection of co-channel interference at the following desired signal levels.

Table 4.1 Co-Channel Rejection Thresholds

Type of Interference	Co-Channel D/U ³ Ratio (dB)	
	Weak Desired (-68 dBm)	Moderate Desired (-53 dBm)
DTV interference into DTV	+15.5	+15.5
NTSC interference into DTV	+2.5	+2.5
<i>Notes:</i> NTSC split 75% color bars with pluge bars should be used for video source. All NTSC values are peak power; all DTV values are average power		

² No attempt has been made to project the channel allocations and operating power levels after the DTV transition. It is possible that due to spectrum repacking, channel combinations after the DTV transition will be tighter than the examples provided in Annex D.

³ Throughout this document, all signal power levels and the ratios of signal power levels are expressed logarithmically in decibels. Signal levels are expressed in dBm (decibels above a milliwatt).

$$P_{\text{dBm}} = 10 \log_{10}(P_{\text{milliwatts}})$$

Ratios of signal levels, such as Desired to Undesired (D/U) signal level ratios, are expressed in dB:

$$P_{\text{D/U}} \text{ dB} = 10 \log_{10}(P_D/P_U)$$

where P_D and P_U are in the same units of watts, milliwatts, microwatts, etc.

The reader should be careful to remember that when the power level of the Desired signal (in watts) is greater than the power level of the Undesired signal (in watts) the sign of the log of the power ratio (D/U in dB) will be positive. When the power level of the Desired signal is less than the power level of the Undesired signal, the sign of the log of the power ratio (D/U in dB) will be negative. For example, when the D/U ratio (in dB) is 25 dB, the power level of the Desired signal is 25 dB above the power level of the undesired signal. When the D/U ratio is -25 dB, the power level of the Desired signal is 25 dB below the power level of the Undesired signal.

4.4.2 First Adjacent Channel Rejection

The receiver should meet or exceed the thresholds given in Table 4.2 for rejection of first adjacent-channel interference at the desired signal levels shown above the columns therein. The FCC Rules prohibit NTSC stations operating on the first upper and/or lower adjacent channels from locating their transmitters closer than 88.5 km apart from one another. Such a restriction limits receivers tuned to a desired station to exposure to first adjacent channel undesired signals only when the desired signal is at the weak signal level. The moderate and strong desired signal levels are included in the table because, in the development of the original DTV allotment table, the FCC Rules did not apply a mileage separation restriction to DTV stations operating on the first upper and/or lower adjacent channels. Allowing a first adjacent channel undesired station to be located anywhere within a desired station's service area, as made possible by the FCC Rules, will expose receivers tuned to that desired station to undesired signals when the desired signal also is at moderate and strong levels.⁴

Table 4.2 First Adjacent Channel Thresholds

Type of Interference	Adjacent Channel D/U Ratio (dB)		
	Weak Desired (-68 dBm)	Moderate Desired (-53 dBm)	Strong Desired (-28 dBm)
Lower DTV interference into DTV	-33 ⁵	-33 ⁶	-20
Upper DTV interference into DTV	-33	-33 ⁶	-20
Lower NTSC interference into DTV	-40	-35	-26
Upper NTSC interference into DTV	-40	-35	-26
<i>Note:</i> All NTSC values are peak power; all DTV values are average power.			

4.4.3 Taboo Channel Rejection

The receiver should not exceed the following thresholds for rejection of taboo-channel interference at the desired signal levels.

⁴ Receiver designers should be aware that, in the U.S., there might be narrow-band transmissions operating on adjacent TV channels. For example, in some cities, vacant TV channels are used for public safety land mobile communications. In addition, the FCC is currently considering whether it will allow unlicensed consumer devices to operate on unused TV channels (see ET docket 02-380).

⁵ The FCC planning factors for DTV into DTV are -26 and -28 in "Reconsideration of the Sixth Report and Order" (FCC 98-24). These were based on asymmetric transmitter splatter in the first adjacent channel. For this document, -27 is used and a 6 dB margin is added to reach -33 D/U. Most test equipment will not generate the FCC-allowed splatter. By meeting the -33 dB guideline with lab generators that do not have side band splatter, it is assured that the limiting interference in the field will be adjacent splatter rather than overload. The margin is added to allow for improvement in DTV transmitter technology.

⁶ The adjacent channel rejection ratio for DTV into moderate DTV is set equal to the ratio for DTV into weak DTV, because of the incidence of predicted DTV into DTV interference at moderate levels. The rejection ratios for NTSC into weak DTV and NTSC into moderate DTV do not need to be equal, due to the use of either co-location or distant spacing of analog and digital transmitters. However, practical receiver designs may attain the same rejection at moderate level as at weak level.

4.4.3.1 DTV Interference into DTV

Table 4.3 Taboo Channel Rejection Thresholds for DTV Interference into DTV

Channel	Taboo Channel D/U Ratio (dB)		
	Weak Desired (-68 dBm)	Moderate Desired (-53 dBm)	Strong Desired (-28 dBm)
N +/- 2	-44	-40	-20
N +/- 3	-48	-40	-20
N +/- 4	-52	-40	-20
N +/- 5	-56	-42	-20
N +/- 6 to N +/- 13	-57	-45	-20
N +/- 14 and 15	-50 ⁷	-45	-20

Notes:
These numbers are consistent with the maximum signal level in Section 4.1.
All NTSC values are peak power; all DTV values are average power.

4.4.3.2 NTSC Interference into DTV

Table 4.4 Taboo Channel Rejection Thresholds for NTSC Interference into DTV

Channel	Taboo Channel D/U Ratio (dB)		
	Weak Desired (-68 dBm)	Moderate Desired (-53 dBm)	Strong Desired (-28 dBm)
N +/- 2	-44	-40	-20
N +/- 3	-48	-40	-20
N +/- 4	-52	-40	-20
N +/- 5	-56	-42	-20
N +/- 6 to N +/- 13	-57	-45	-20
N +/- 14 and 15	-50	-45	-20

Notes:
NTSC split 75% color bars with pluge bars should be used for video source.
All NTSC values are peak power ; all DTV values are average power.

4.4.4 Burst Noise Performance

The receiver should tolerate a noise burst of at least 165 μ s duration at a 10 Hz repetition rate without visible errors. The noise burst should be generated by gating a white noise source with average power -5 dB, measured in the 6 MHz channel under test, referenced to the average power of the DTV signal.

⁷ This value should not be interpreted as just a tuner image rejection value in that it applies to the entire receiver.

4.5 Multipath

4.5.1 Introduction

The aim of this section is to focus on real field multipath propagation conditions and on the practical difficulties DTV demodulator designers may encounter. Equalizer design techniques are not addressed, as equalizer design is a topic that has been widely documented in specialized literature over the past years.

Field studies of DTV signal reception have demonstrated a wide range of varying multipath and noise conditions. It is generally admitted that there is no adequate model representing the diversity of conditions observed in the field. Past experience has proven that there is a clear benefit in gaining knowledge from the field environment to improve receiver performance.

This section provides information and recommendations regarding the multipath conditions that may be experienced in the field. The recommendations consist of two complementary parts, which are digitally captured signals obtained in actual field conditions and selected multipath ensembles created using laboratory test equipment.

In the first part of this section, a dataset of field ensembles (DTV captured signals) is furnished as an example of the various conditions that can be observed in the field. Most of the field ensembles contain data captured at sites where reception was difficult. The field ensembles are clearly not meant to represent the statistics of overall reception conditions but rather to serve as examples of difficulties that are commonly experienced in the field. A few mild ensembles are included in the data so that receiver design does not focus solely on new difficult conditions, overlooking performance requirements shown to be necessary in the past.

In the second part of the section, recommendations on laboratory ensembles are proposed. The laboratory ensembles do not necessarily represent actual channel conditions, nor do they represent design criteria. The ensembles are intended to be supplementary diagnostic tools for testing designs in specific controlled conditions. Some element of variability of the relevant parameters was introduced in the laboratory ensembles to allow the diagnostics to operate with a wide set of characteristics. When possible, a bound on the variable parameters will be suggested to avoid an over-design of the receiver and to allow for proper trade-offs.

4.5.2 Field Ensembles

The data include different scenarios of field capture.

4.5.2.1 Capture Location

The field ensembles recommended in this document were recorded in the Washington, D.C., area and in New York City. The ensembles were chosen for their difficulty, considering past knowledge gained with various generations of DTV receivers and multiple field test campaigns.

The data includes outdoor and indoor captures in different types of environments, such as rural, residential, and suburban areas.

4.5.2.2 List of Recommended Field Ensembles

The list of the recommended field ensembles is provided in Annex A.

4.5.2.3 Field Ensemble Characterization

Each field ensemble is described by a series of labels that characterize the properties of the channel for the specific location in which the RF signal was recorded. The labels are categorized and summarized in Table 4.5. These labels describe the conditions at the time of the data capture and provide the channel characteristics. The receiver designer may use this information to gain insight regarding which areas of the receiver design may require specific care. For example, the dynamic nature of the channel, the distortion of the spectrum band-edge, and the cancellation of the pilot tone are elements that may affect the ability of the receiver to synchronize with the signal and, therefore, may contribute to a failure of the receiver. The design of the receiver could be adapted accordingly to mitigate the effects of these impairment classes.

Table 4.5 Field Ensemble Description

Capture Description			
<i>Antenna Type</i> Log-periodic Dipole Double bow-tie	<i>Antenna Direction Optimization</i> Optimal Random	<i>Capture Parameters</i> AGC on/off A/D precision Others	
Site Description			
<i>Antenna Location</i> In-home Outdoor, 30 feet	<i>Neighborhood Description</i> Rural Industrial park Suburban Others	<i>Site Location</i> Distance from transmitter Latitude/longitude of the site location	<i>Miscellaneous</i> Channel name Date of capture Weather conditions On site temperature Construction type Others
Channel Description			
<i>Upper/Lower Adjacent Channel</i> DTV NTSC None		<i>Channel Dominant Characteristics</i> Multiple echoes Dynamic/static channel In-band interference Band-edge distortion Pilot distortion Others	

A detailed description of all the labels is given in Annex A.

The labels associated with the ensembles listed in Annex A can be divided into three types of information representing a description of the site where the signal was recorded:

- The capture methodology
- Site where the signal was recorded
- Nature of the signal itself

The capture description is broken down into three categories:

- The type of antenna used to record the channel
- Optimization of the antenna direction

- Additional capture parameters, such as whether or not an AGC (Automatic Gain Control) was used during the capture of the channel, the analog-to-digital (A/D) converter precision, and so on

The site description specifies the context in which each field ensemble was recorded. This information is broken down into four categories:

- The site location
- Neighborhood description
- Antenna location
- Miscellaneous information, such as, the name of the file, the capture date, the recorded channel, the weather conditions during the capture of the signal, and so on

The channel description is broken down into two parts that specify the presence and type of upper and lower adjacent channels and a characterization of the nature of the captured channel. This characterization is intended to enable receiver designers to better assess the relative difficulty of each ensemble.

The channel characteristics have been extracted from observations of the channel spectrum over the entire period of the capture. The echo profiles of some captured channels have been explicitly identified and documented in Annex B, when the profile was felt to provide useful information in terms of channel diversity conditions. The impulse response estimate is produced by a correlation between the received signal and the PN511 binary training sequence embedded in the data field sync (see A/53C [3]). The impulse response produces a channel estimate with a maximum echo span of $-23 \mu\text{s}$ (for pre-echo) and $+23 \mu\text{s}$ (for post-echo) for every data field sync segment. A more detailed description of the channel estimation technique is given in Annex B.

4.5.2.4 Data Format

All field ensembles in Annex A represent a digital record having a maximum length of 25 seconds of 8-VSB DTV broadcast. The field ensembles were coded into a unique data format chosen for its compatibility with standard RF playback equipment.

The recorded DTV channels were sampled at 21.524476 Msamples/sec and down converted to a Low central IF frequency of 5.38 MHz. The analog-to-digital conversion of the RF signal used a 10-bit or a 12-bit A/D. Each sample was encoded into a 2-byte word (signed int16 with a two's complement format). To encode a field ensemble of 25 seconds, 1.05 G Bytes were needed.

4.5.2.5 Recommended Physical Support for Field Ensemble Data Transfer

To play back the data on RF player equipment (such as a Sencore RFP 910), three options are possible:

- The data can be transferred to an Integrated Device Electronics (IDE) hard drive (the Sencore RFP 910 includes a 60 G Byte hard drive)
- A tape drive (Exabyte-compatible) can be used
- An external Small Computer Systems Interface (SCSI) hard drive can be used.

The last option is recommended as it allows a flexible transfer of all the recommended field ensembles in a single transaction from the ensemble database repository.

The recommended field ensembles set is available by request to the ATSC.

4.5.3 Laboratory Ensembles

The emulation of realistic field conditions in a laboratory environment is considered to be difficult at best. The difficulty lies, in part, in the inability to create models for a wide range of multipath conditions and also, in part, in historical technical limitations of laboratory test equipment, which allows only borderline case tests.

Laboratory test ensembles are widely used, however, and are considered to be useful, in specific cases, for stressing the performance of DTV receivers within a controlled laboratory environment.

A minimal set of exemplary laboratory diagnostic ensembles is proposed, in the sections below, as a set of diagnostic tools for receiver design. The ensembles proposed in this section were selected or constructed based upon judgment of their utility by the members of the committee preparing this Recommended Practice. The ensembles have been selected for their ability to trigger specific failure mechanisms in receivers. When possible, a document reference stating the origin of a selected laboratory ensemble is furnished. To guarantee at least a minimal correlation with observations in the field, the laboratory diagnostic ensembles have been substantiated by a time domain analysis of field ensembles that were extracted from the field ensembles database Annex A (which were selected for their apparent difficulties and rough correlation with the laboratory ensembles). A summary of the analysis is furnished in Annex B. Finally, to allow for flexibility, the selected laboratory ensembles have been modified to allow for use of variable parameters.

The ensembles described in Section 4.5.3.2 are offered as a recommended tool for evaluating DTV receiver performance.

4.5.3.1 Channel Impulse Response Range

4.5.3.1.1 Typical Echo Range

The typical channel impulse response for a signal from a single DTV transmitter ranges from $-10\ \mu\text{s}$ (pre-echo) to $+40\ \mu\text{s}$ (post-echo). This range is not to be taken as absolute but rather as what has commonly been observed in the field and what the experts preparing this Recommended Practice recommend as the minimum echo range that should be compensated by the receiver.

As is shown by the captured ensembles proposed in Annex C, it is clearly possible that there are channel impulse responses exhibiting echoes beyond this range. However, to the best of our knowledge, there is no data available to scientifically assess the probability of occurrence of any particular channel estimate for any particular time period.

A test for this capability should vary the echo offset over the range. The step size should not be the exact symbol time. A plot of single echo amplitude vs. displacement over this range (or greater) should aid in showing the performance of a design in this regard.

4.5.3.1.2 Single Static Echoes Amplitude / Equalizer Profile

Figure 4.3 describes the magnitude of the channel impulse response profile for which the receiver should perform in a static or quasi-static condition.

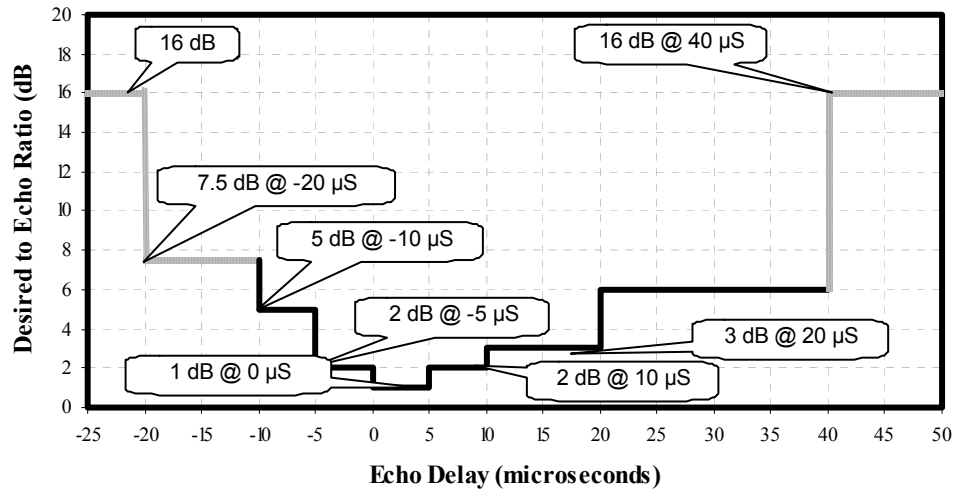

Figure 4.3 Recommended target performance for a desired DTV signal in the presence of a single static echo of varying delay.

To make the test procedure insensitive to the phase of the single echo channel, a slow Doppler of 0.05 Hz^8 is introduced. In the presence of a single echo, performance should be determined by TOV with a desired DTV signal power of -28 dBm to the limits defined by the profile.

The profile is segmented into two parts. The unbroken line between $-10 \mu\text{s}$ and $+40 \mu\text{s}$ represents the single-echo profile that should be compensated by the equalizer. The broken lines between $-25 \mu\text{s}$ and $-10 \mu\text{s}$ and between $+40 \mu\text{s}$ and $+50 \mu\text{s}$ represent suggested profiles outside the recommended minimum equalizer span range. It is important to note that the entire profile has been shifted upwards by 1 dB, compared to the maximum echo amplitude noted in some field conditions, to compensate for the additional equalizer constraint introduced by the slow Doppler and to allow more repeatable laboratory tests.

For example, the profile in the region of 0 to $5 \mu\text{s}$ was derived from DTV field observations that have shown that the amplitude of the multipath echoes within that range could reach 0dB. Such examples can be found in the New York City indoor field ensembles captured by the Advanced Television Technology Center (ATTC), as shown in Annex B. The New York captures utilized various antenna types oriented to obtain an optimum frequency spectrum in terms of amplitude and flatness. The capture location was a fourth-floor urban apartment constructed of wood with brick siding. The room had windows on two adjacent walls. The profile of the region outside the 0 to $5 \mu\text{s}$ range, but within the recommended span range, is thought to be a reasonable range achievable by current technology. Increasing the range for processing large echoes as technology improves should increase the number of locations where receivers can operate, but the point of diminishing returns is not known.

⁸ Some equipment may not have the required resolution. In such case, using the slowest Doppler rate above 0.05Hz that is available is recommended.

The lowest point of the curve indicates the boundary between post and pre echoes. The pre echo and post echo regions of the profile should not be interpreted as a parameterization of the forward and feedback filters of the DFE equalizer type architecture.

4.5.3.2 Single Dynamic Echoes

The ensembles proposed below (ATSC R.1⁹) attempt to create single echo scenarios where the echo path and the dominant path may reverse roles if the echo power is sufficiently strong. ATSC R.1 ensembles allow for variability of the main parameters.

The following table describes the ensemble test:

Table 4.6 ATSC Test Group R.1. Multiple Dynamic Echoes

ATSC Test Group	Test Impairment	Test Description	Desired Signal Level
Susceptibility to Dynamic Echoes in the Presence of Random Noise	R.1 Dynamic Alternating Pre- and Post-Echoes in the presence of noise	<ol style="list-style-type: none"> 1. Variable Pre/Post 2. Delay, attenuation, and phase set per table below 3. Test with path 3 at variable Doppler; path 2 at 0.05 Hz 4. Increase echo power level of paths 2 and 3 together to determine TOV 	Strong (-28 dBm)

The actual generation of the single dynamic echoes is achieved using the following path parameters in a six-channel simulator. Path 1 is the main path. Paths 2 and 3 have identical delays. The phase of path 3 is varied at specific Doppler rates. Consequently, the voltages of the two paths (2 and 3) add vectorially, constructively or destructively, according to the phase. The attenuation of echo paths 2 and 3 are varied such that the power of each echo is maintained at an equal level.

The path parameters are given below in Table 4.7.

Table 4.7 ATSC R.1 Ensembles

ATSC Ensemble	Channel Simulator Parameter	Path 1	Path 2	Path 3
ATSC R.1	Delay (μ s)	0	Variable	Variable (Identical to Path #2)
	Attenuation (dB)	0	Variable	Variable (Identical to Path #2)
	Phase (deg.)	0	0.05 Hz Doppler	Variable (0 – 2Hz)

The relative time domain delay between the two signals (that of the main path and the resultant of the time varying combination of paths 2 and 3) should be variable. Note that the phase variations on each path will result in a time varying echo amplitude for each test point. It is recommended that the time delay range be from the smallest step supported by the test

⁹ ATSC R.1 is derived from the ATSC Group G.1.1 and G.1.2 (DTV Laboratory Test Plan, Revision 1.0, October 11, 2001).

equipment up to 2 μ s (the same setting for both path 2 and 3 for each test). It is recommended that the attenuation (the same setting for both path 2 and 3 for each test) should be varied from 7 dB to 0 dB. Although there is some evidence of “bobbing” channels (i.e., channels where the dominant signal path changes among two or more approximately equal echoes) beyond the 2 μ s range, experts in the area consider that even the 2 μ s range may be challenging for some equalizer designs.

An example of such a multipath ensemble was observed in the ATTC outdoor signal capture WAS-311/48/01. It seems to indicate the presence of close-in alternating echoes with a span between echoes of about 300ns. Another example of such a channel is furnished in the signal capture WAS-049/36/01¹⁰ with a span between echoes of 1.75 μ s. The impulse response analysis of these two ensembles is furnished in Annex B. Other capture signals presenting a similar phenomenon are WAS-114/27/01¹⁰, WAS-114/39/01¹⁰, and WAS-101/48/01¹⁰.

This test was chosen for its repeatability in laboratory conditions. Other models for alternating pre- and post-echoes can be proposed. For example, conditions such as Rayleigh fading attenuation could be investigated.

4.5.3.3 Multiple Dynamic Echo Ensembles

A series of multiple dynamic echo ensembles represented by the test ATSC R.2¹¹ is offered as a means to provide increasingly more difficult multipath conditions to a DTV receiver. These ensembles are described in Table 4.8.

Table 4.8 ATSC Test Group R.2. Multiple Static and Dynamic Echoes

ATSC Test Group	Test Impairment	Test Description	Desired Signal Level
Susceptibility to Dynamic Echoes in the Presence of Random Noise	R.2 Dynamic Echoes in the presence of noise	R.2.1. Dynamic Ensemble #1/ #2 / # 3 / #4 1. Test with path 5 at variable Doppler (0-5Hz) 2. Increase power of path 5 to determine TOV	Moderate (-53 dBm)
		R.2.2 Dynamic Ensemble # 1/ # 2 / # 3 1. Test at variable S/N levels 2. Test with path 5 variable Doppler (0 – 5Hz)	Moderate (-53 dBm)

The actual generation of the single dynamic echo for the ensemble ATSC R.2.1 is achieved using the path parameters defined in Table 4.9 in a six-path channel simulator. Path 1 is the main path.

¹⁰ Although interesting from the multipath point of view, this channel has not been included in the recommended set of field ensembles, as it has been determined that the channel may be affected by capture equipment artifacts.

¹¹ These ensembles were derived from a set of CRC (Communications Research Center, Canada) ensembles, which in turn were derived from an ensemble in “Grand Alliance System Test Procedures,” Advisory Committee on Advanced Television Service, Federal Communications Commission, SSWP2-1306, March 24, 1995.

Table 4.9 ATSC R2.1 Ensembles

Ensemble		Path 1	Path 2	Path 3	Path 4	Path 5	Path 6
Relative attenuation (dB)	#1	0	20	20	10	Varied to reach TOV	18
	#2	0	17	17	7		15
	#3	0	14	14	4		12
	#4	0	11	11	1		9
Delay (μ sec)		0	-1.80	0.15	1.80	5.70	35.0
Phase or Doppler		0	125°	80°	45°	Variable (0–5 Hz)	90°

ATSC R2.1 includes a variable Doppler shift for the Path 5. The recommended range for the variable Doppler is 0 to 5Hz.

Table 4.10 ATSC R2.2 Ensembles

Ensemble		Path 1	Path 2	Path 3	Path 4	Path 5	Path 6
Relative attenuation (dB)	#1	0	15	15	7	7	15
	#2	0	8	3	4	3	12
	#3	0	3	1	1	3	9
Delay (μ sec)			-1.8	0.15	1.8	5.7	39.8
Phase or Doppler		0	125°	80°	45°	Variable (0–5 Hz)	90°
White Gaussian Noise		Variable					

The ATSC R.2.2 ensembles are created to explore the ability of a design to operate with increasing additive Gaussian noise in the presence of five echoes of various relative amplitudes (see Table 4.10). The proposed set explores equalizer performance in regions where Path 6 is at the boundary of the recommended range for the equalizer delay span. The ATSC R.2.2 modifications include the introduction of a variable level of Additive White Gaussian Noise (AWGN) and a displacement of the echo delay in Path 6 from 35 μ s to 40 μ s.

The power in Path 1 should be set at the practical limit¹² of the test bed, and white Gaussian noise should be added until the SNR is at least reduced to 18 dB. This minimal SNR value was recommended by the experts preparing this Recommended Practice for practical equalizer designs known in late 2003. The 18 dB SNR incorporates a 3dB margin over the theoretical ATSC 8-VSB SNR defined in the absence of multipath. The 3dB margin takes into account the effects of noise enhancement introduced by the equalizer. Operation with lower SNRs is desirable and expected to approach the theoretical limit for a given architecture and under given multipath conditions as receiver designs become more mature. To avoid a variability of the SNR with respect to the delay of the estimated signal source, the signal power should be calculated for each test sequence by adding the absolute values of the power in all six paths. The noise power should be calculated over a 6 MHz bandwidth.

¹² Note that total power, including the to-be-added noise, should be considered in determining what this starting level should be to avoid introducing distortions from the test bed.

Threshold of operation is measured at a transport stream bit-error-rate (BER) of 3×10^{-6} .

4.5.3.4 Dynamic Multipath in the Presence of Doppler Frequency Shift and Airplane Flutter

The reception of the DTV signal in the presence of multipath may also be influenced by Doppler shift and airplane flutter if the reflecting object is moving. Doppler shift is an apparent change in frequency (or wavelength) due to the relative motion of the reflecting object with respect to the receiver. The exact analytical expression of the Doppler frequency shift (F_D) is related to the velocity of the reflecting object (V_R) relative to the signal path and the DTV channel frequency (F_{TV}) by the following equation:

$$F_D = V_R \times [\pm \cos(\theta_T) \pm \cos(\theta_R)] \times F_{TV} / c \quad (1)$$

where c is the speed of light, and θ_T and θ_R are the angles between the velocity direction of the reflecting object and the paths between the reflecting object and the transmitter and receiver, respectively.

Benson¹³ reports that airplane flutter occurs at rates from 50 to 150 Hz. These rates have also been observed in DTV field signal captures. In particular, the indoor capture at site WAS-32/39/01⁴ shows rates as high as 75 Hz in an 11 μ s echo with amplitude of -25 dB and rates in the order of 17 Hz with echo amplitude of -9 dB with respect to the dominant signal path. This capture was taken in a single-family home approximately 19 miles from the transmitter and within several miles from IAD airport. A double bow-tie antenna with reflector was used and was aimed to optimize the signal spectrum. From equation (1) the relative object velocity for a 75 Hz Doppler at channel 39 (623 MHz) is 160 mph (assuming a positive Doppler frequency shift). This is a reasonable velocity if the echo is due to the presence of aircraft. The indoor capture at site WAS-49/36/01⁴ shows Doppler rates that range between 17 Hz with a 1.75 μ s echo with amplitude of echo of -5 dB up to 150 Hz with echo amplitude between -20 dB and -30 dB. This site was a single-family home near the BWI airport. An aircraft was observed flying towards the receiver during the capture. Since these Doppler rates have been observed in the field, it is recommended that a limited number of laboratory test ensembles include variations in Doppler frequency from zero to 150 Hz..

Due to the limited amount of data, it was not possible to define a correlation between the echo profile and the Doppler shift.

4.6 Antenna Interface

The sections on multipath have described many signal conditions where reception is difficult. Furthermore, in the sections on sensitivity and overload, the authors of this document considered reception conditions made difficult by low received signal strength or by potential overload from large received signals. In some cases, reception can be improved with an antenna that has a more directional pattern than a dipole. Controlled amplification between the antenna and the tuner sometimes can be helpful.

Automatically controlled antenna- and pre-amplifier-based improvements in reception can be facilitated by including in the receiver the “Antenna Control Interface” described in the CEA-909 Standard [7]. CEA-909 defines an interface that can control an antenna’s

¹³ K. B. Benson, et. al.: “Television Reception Principles”, *Standard Handbook of Video and Television Engineering*, Chapter 17.1, McGraw-Hill, New York, N.Y., 2000.

directionality, polarization, pre-amplifier gain, and tuning optimization for a particular channel. The digital link is by a serial bit stream, with specified connector, voltage levels and bit assignments. The standard allows any antenna to work with any receiver, as long as both support the interface. The performance of the antenna is not specified, nor is the receiver algorithm that optimizes the antenna configuration for a particular received signal. These are areas for competitive innovation.

It is expected that a controllable antenna will work in conjunction with a receiver's equalizer, tuner, and demodulator to improve reception under conditions of multipath and unusually weak or strong signals. In some cases, an antenna with a directional pattern that gives only a few dB reduction of a specific multipath reflection can dramatically improve the equalizer's performance. Such modest directional performance can be achieved with antennas of consumer-friendly size, especially at UHF.

The CEA-909 interface describes fully automatic operation of the antenna and its control functions. It also allows the option for manual programming by the consumer.

In addition to the other guidelines contained herein for the handling of signal conditions that are experienced in the field, consideration of a receiver-controlled antenna, as enabled by CEA-909, is recommended.

4.7 Consumer Interface—Received Signal Quality Indicator

The capability to display received signal quality conditions on a quasi-real time basis is a feature that should be included in all digital broadcast receivers.

Unlike analog reception, transmission impairments such as echo, interference and noise do not manifest themselves in uniquely identifiable ways in a digital broadcast receiver's display. Reception and display of digital signals on a digital receiver is largely a "go-no go" experience for the consumer, and the received picture or audio by themselves offer little useful guidance as to the relative difficulty of the current reception conditions.

A digital broadcast receiver's digital signal quality indicator should be more than simply a signal strength meter, and should take into account the effects of multipath and interference impairments, as well as insufficient or excessive signal level. Moreover, the signal indicator should be easy to understand, intuitive to use and easy to access for a consumer in order to effectively position or aim an antenna, judge the need or effectiveness of additional front end amplification and/or aid in other user-controlled adjustments to optimize the receiver's configuration with respect to the current reception conditions.

Receiver manufacturers should consider two applications of indicator displays; setup displays and operational displays. Each application should provide some manner of signal level indication as well as indications of the effects of multipath and interference impairments. Setup displays should be persistent to facilitate the installer's achieving proper system alignment. Operational displays may be transient or under user control if desired. User options should be provided in both categories.

Means to achieve such signal quality indications should be left to the judgment of individual receiver manufacturers.

Annex A: Capture Labels and Descriptions

The recommended ATSC set of RF captured field ensembles is listed in Figure A.1 (see next page). A detailed description of the labels associated with each ensemble is given below.

Column	Description
Site Name	A unique identifier to label the ATSC capture data.
City	City where the data was collected.
State	State where the data was collected.
Date	The date when the data was collected.
Channel	The RF television channel of the capture data.
Type of capture	Location where data was collected (i.e. in-home, outdoor).
Length of capture	Length of the capture data in seconds.
Quality of Capture	Whether the data contains errors or gaps (i.e., symbol errors, drops, etc.).
Latitude	Geographic coordinates (latitude) of where the data was collected.
Longitude	Geographic coordinates (longitude) of where the data was collected.
Distance from transmitter	Distance in miles between the transmitter and the receiver (i.e., capture device).
Lower adjacent	Whether a first lower adjacent television station (NTSC or DTV) was operating when the capture was collected.
Upper adjacent	Whether a first upper adjacent television station (NTSC or DTV) was operating when the capture was collected.
Neighborhood description	Description of the surroundings where the data was collected.
Location type	Description of the location of the structure near or where the data was collected.
Antenna location	A more detailed description of the location of where the data was collected (i.e., bedroom, living room, outdoor).
Antenna height	Approximate height above ground of the receive antenna where the data was collected.
Antenna type	Type of antenna used during the data collection.
Antenna orientation	Orientation of the antenna (i.e., Optimal, Random). Optimal orientation was achieved when the waveform on the spectrum analyzer exhibited maximum amplitude and best flatness .
Construction type	The construction of the structure near or where the data was collected.
Siding	Exterior shell of the structure where data was collected.
Weather conditions	Weather conditions when the data was collected.
Temperature	Temperature in Fahrenheit when the data was collected.
Data captured by	Owner(s) of the captured data.
Data format	Resolution and format of the data.

AGC	Whether an AGC was used during the capture.
SAW	The bandwidth of the SAW filter used for the capture device.
Original data capture	Name of the file where the data was originally captured.
Demodulated by current receivers	This column states whether the data was demodulated by different generations of receivers. The information in this column is based on testing that was conducted by MSTV in December of 2003 and used three separate receiver generations. The latest prototype receiver is identified as a third generation receiver.
Capture comments	Special comments that were collected during the capture.
Single echo	Examination of the waveform on a spectrum analyzer to determine whether the waveform exhibited conditions that suggested the presence of a single predominant echo.
Close-in echoe(s)	Examination of the waveform on a spectrum analyzer to determine whether the waveform exhibited conditions that suggested the presence of a close-in echoe(s).
Multiple echoes	Examination of the waveform on a spectrum analyzer to determine whether the waveform exhibited conditions that suggested the presence of a multiple echoes.
Deep notche(s)	Examination of the waveform on a spectrum analyzer to determine whether the waveform exhibited conditions that suggested the presence of deep and narrow notches in the order of 10 dB or more during the capture. When this entry is filled in along with the next entry (wide notches) it means that the notches are deep (greater than 10 dB) and wide (100 KHz or more).
Wide notche(s)	Examination of the waveform on a spectrum analyzer to determine whether the waveform exhibited conditions that suggested the presence of wide notches, in the order of 100 KHz or more.
Flat fading	Examination of the waveform on a spectrum analyzer to determine whether the waveform is generally flat within the 6 MHz bandwidth and changing in amplitude.
Band-edge distortion	Examination of the waveform on a spectrum analyzer to determine whether the waveform exhibited conditions that suggested the presence of distortion at the edge of the 6 MHz bandwidth, such as a tilt (more than 8 dB) or deep notch during the capture.
Pilot notch	Examination of the waveform on a spectrum analyzer to determine whether the waveform exhibited conditions that suggested the loss or severe notching of the pilot during the capture.
Static	Examination of the waveform on a spectrum analyzer to determine whether the waveform exhibited only static conditions during the capture.
Slow dynamic	Examination of the waveform on a spectrum analyzer to determine whether the waveform exhibited slowly varying dynamic conditions during the capture.
Moderate dynamic	Examination of the waveform on a spectrum analyzer to determine whether the waveform exhibited moderately varying dynamic conditions during the capture.
Fast dynamic	Examination of the waveform on a spectrum analyzer to determine whether the waveform exhibited fast-moving dynamic conditions during the capture.
Irregular dynamic	Examination of the waveform on a spectrum analyzer to determine whether the waveform exhibited dynamic conditions that changed from fast to slow to moderate or vice versa during the capture.
Regular dynamic	Examination of the waveform on a spectrum analyzer to determine whether the waveform exhibited dynamic conditions that did not change during the capture.
In-band interference	Examination of the waveform on a spectrum analyzer to determine the presence of other factors outside the 6 MHz bandwidth of the signal (i.e., contribution of adjacent channel, etc.).

Figure A.1 RF capture spreadsheet (next 9 pages). (*Note: an electronic version of this Microsoft Excel document is available from ATSC.*)

	A	B	C	D	E	F	G
1	Site Name	City	State	Date	Channel	Type of Capture	Length of Capture (sec)
2	NYC/209/44/01	NYC	NY	10/27/2000	44	in-home	23
3	NYC/202/44/01	NYC	NY	10/27/2000	44	in-home	23
4	NYC/200/44/01	NYC	NY	10/27/2000	44	in-home	23
5	NYC/208/44/01	NYC	NY	10/27/2000	44	in-home	23
6	NYC/205/44/01	NYC	NY	10/27/2000	44	in-home	23
7	NYC/206/44/01	NYC	NY	10/27/2000	44	in-home	23
8	NYC/204/44/01	NYC	NY	10/27/2000	44	in-home	23
9	NYC/207/44/01	NYC	NY	10/27/2000	44	in-home	23
10	NYC/217/56/01	NYC	NY	10/27/2000	56	in-home	23
11	NYC/215/56/01	NYC	NY	10/27/2000	56	in-home	23
12	NYC/212/56/01	NYC	NY	10/27/2000	56	in-home	23
13	NYC/211/56/01	NYC	NY	10/27/2000	56	in-home	23
14	NYC/216/56/01	NYC	NY	10/27/2000	56	in-home	23
15	NYC/218/56/01	NYC	NY	10/27/2000	56	in-home	23
16	NYC/210/56/01	NYC	NY	10/27/2000	56	in-home	23
17	NYC/213/56/01	NYC	NY	10/27/2000	56	in-home	23
18	NYC/219/56/01	NYC	NY	10/27/2000	56	in-home	23
19	WAS-006/34/01	Washington	DC	6/9/2000	34	Outdoor-30 feet	25
20	WAS-023/34/01	Washington	DC	6/7/2000	34	in-home	25
21	WAS-023/48/01	Washington	DC	6/7/2000	48	in-home	25
22	WAS-003/27/01	Washington	DC	6/2/2000	27	Outdoor-30 feet	25
23	WAS-003/35/01	Washington	DC	6/2/2000	35	Outdoor-30 feet	25
24	WAS-311/34/01	Washington	DC	6/5/2000	34	in-home	25
25	WAS-311/35/01	Washington	DC	6/5/2000	35	Outdoor-30 feet	25
26	WAS-311/36/01	Washington	DC	6/5/2000	36	Outdoor-30 feet	25
27	WAS-311/39/01	Washington	DC	6/5/2000	39	in-home	25
28	WAS-311/48/01	Washington	DC	6/5/2000	48	Outdoor-30 feet	25
29	WAS-032/48/01	Washington	DC	6/1/2000	48	in-home	25
30	WAS-034/27/01	Washington	DC	6/8/2000	27	in-home	25
31	WAS-034/35/01	Washington	DC	6/8/2000	35	in-home	25
32	WAS-034/48/01	Washington	DC	6/8/2000	48	in-home	25
33	WAS-038/34/01	Washington	DC	5/31/2000	34	in-home	25
34	WAS-038/34/01	Washington	DC	5/31/2000	34	Outdoor-30 feet	25
35	WAS-038/36/01	Washington	DC	5/31/2000	36	in-home	25
36	WAS-047/48/01	Washington	DC	6/13/2000	48	in-home	25
37	WAS-049/34/01	Washington	DC	6/14/2000	34	in-home	25
38	WAS-049/39/01	Washington	DC	6/14/2000	39	in-home	25
39	WAS-051/35/01	Washington	DC	5/24/2000	35	Outdoor-30 feet	25
40	WAS-063/34/01	Washington	DC	6/21/2000	34	in-home	25
41	WAS-068/36/01	Washington	DC	5/23/2000	36	Outdoor-30 feet	25
42	WAS-075/35/01	Washington	DC	6/16/2000	35	in-home	25
43	WAS-075/36/01	Washington	DC	6/16/2000	36	in-home	25
44	WAS-075/39/01	Washington	DC	6/16/2000	39	in-home	25
45	WAS-080/35/01	Washington	DC	6/15/2000	35	in-home	25
46	WAS-081/36/01	Washington	DC	6/19/2000	36	in-home	25
47	WAS-082/35/01	Washington	DC	6/20/2000	35	in-home	25
48	WAS-083/36/01	Washington	DC	6/22/2000	36	in-home	25
49	WAS-083/39/01	Washington	DC	6/22/2000	39	in-home	25
50	WAS-086/36/01	Washington	DC	7/12/2000	36	in-home	25
51	WAS-086/48/01	Washington	DC	7/12/2000	48	Outdoor-30 feet	25
52							
53							
54							
55							

	A	H	I	J	K	L	M
					Distance from Transmitter (M)	lower adjacent (n-1)	Upper Adjacent (n+1)
1	Site Name	Quality of Capture	Latitude	Longitude			
2	NYC/209/44/01	good/no error	40-46-35	73-58-39	2.00		
3	NYC/202/44/01	good/no error	40-46-35	73-58-39	2.00		
4	NYC/200/44/01	good/no error	40-46-35	73-58-39	2.00		
5	NYC/208/44/01	good/no error	40-46-35	73-58-39	2.00		
6	NYC/205/44/01	good/no error	40-46-35	73-58-39	2.00		
7	NYC/206/44/01	good/no error	40-46-35	73-58-39	2.00		
8	NYC/204/44/01	good/no error	40-46-35	73-58-39	2.00		
9	NYC/207/44/01	good/no error	40-46-35	73-58-39	2.00		
10	NYC/217/56/01	good/no error	40-46-35	73-58-39	2.00		
11	NYC/215/56/01	good/no error	40-46-35	73-58-39	2.00		
12	NYC/212/56/01	good/no error	40-46-35	73-58-39	2.00		
13	NYC/211/56/01	good/no error	40-46-35	73-58-39	2.00		
14	NYC/216/56/01	good/no error	40-46-35	73-58-39	2.00		
15	NYC/218/56/01	good/no error	40-46-35	73-58-39	2.00		
16	NYC/210/56/01	good/no error	40-46-35	73-58-39	2.00		
17	NYC/213/56/01	good/no error	40-46-35	73-58-39	2.00		
18	NYC/219/56/01	good/no error	40-46-35	73-58-39	2.00		
19	WAS-006/34/01	good/no error	38-55-1	77-16-27	10.76	none	DTV
20	WAS-023/34/01	good/no error	38-49-23	77-20-32	16.71	none	DTV
21	WAS-023/48/01	good/no error	38-49-23	77-20-32	15.49	none	none
22	WAS-003/27/01	good/no error	38-11-46	77-11-31	48.41	NTSC	none
23	WAS-003/35/01	good/no error	38-11-46	77-11-31	51.91	DTV	DTV
24	WAS-311/34/01	good/no error**	38-53-17	77-4-21	4.34	none	DTV
25	WAS-311/35/01	good/no error	38-53-17	77-4-21	3.86	DTV	DTV
26	WAS-311/36/01	see capture comments	38-53-17	77-4-21	4.74	DTV	none
27	WAS-311/39/01	good/no error	38-53-17	77-4-21	4.34	none	none
28	WAS-311/48/01	see capture comments	38-53-17	77-4-21	3.86	none	none
29	WAS-032/48/01	good/no error**	38-52-48	77-25-6	17.80	none	none
30	WAS-034/27/01	good/no error	38-48-35	77-2-27	7.53	NTSC	none
31	WAS-034/35/01	good/no error**	38-48-35	77-2-27	9.57	DTV	DTV
32	WAS-034/48/01	good/no error	38-48-35	77-2-27	9.57	none	none
33	WAS-038/34/01	48symbols dropped@14.9905 sec	39-2-50	76-50-44	14.32	none	DTV
34	WAS-038/34/01	48 symbols dropped@15.07375 sec	39-2-50	76-50-44	14.32	none	DTV
35	WAS-038/36/01	48 symbols dropped@22.2029 sec	39-2-50	76-50-44	14.28	DTV	none
36	WAS-047/48/01	48 symbols dropped@13.773 sec	38-47-33	77-14-53	13.07	none	none
37	WAS-049/34/01	Possible symbols dropped**	39-10-58	76-51-23	20.15	none	DTV
38	WAS-049/39/01	48 symbols dropped@24.855 sec	39-10-58	76-51-23	20.15	none	none
39	WAS-051/35/01	good/no error	38-55-44	76-43-22	20.29	DTV	DTV
40	WAS-063/34/01	good/no error	38-46-10	77-6-38	12.66	none	DTV
41	WAS-068/36/01	good/no error**	38-44-34	76-54-8	17.72	DTV	none
42	WAS-075/35/01	good/no error	38-47-58	77-3-32	9.99	DTV	DTV
43	WAS-075/36/01	good/no error**	38-47-58	77-3-32	10.93	DTV	none
44	WAS-075/39/01	good/no error	38-47-58	77-3-32	10.53	none	none
45	WAS-080/35/01	good/no error	38-47-52	77-6-24	9.88	DTV	DTV
46	WAS-081/36/01	good/no error	38-50-32	77-11-6	9.64	DTV	none
47	WAS-082/35/01	48 symbols dropped@17.1644 sec	38-50-51	77-11-38	8.25	DTV	DTV
48	WAS-083/36/01	48 symbols dropped@14.8805 sec	38-54-36	77-3-26	3.46	DTV	none
49	WAS-083/39/01	48 symbols dropped@12.1696 sec	38-54-36	77-3-26	3.05	none	none
50	WAS-086/36/01	good/no error	39-5-2	76-29-18	33.27	DTV	none
51	WAS-086/48/01	good/no error	39-5-2	76-29-18	34.38	none	none
52							
53							
54		** Due to imperfections in the recording device, these vectors, where strong adjacent channel signals were present, may be affected by non linear phenomena					
55							

	A	N	O
1	Site Name	Neighborhood Description	Location Type
2	NYC/209/44/01	Urban apartments	High rises
3	NYC/202/44/01	Urban apartments	High rises
4	NYC/200/44/01	Urban apartments	High rises
5	NYC/208/44/01	Urban apartments	High rises
6	NYC/205/44/01	Urban apartments	High rises
7	NYC/206/44/01	Urban apartments	High rises
8	NYC/204/44/01	Urban apartments	High rises
9	NYC/207/44/01	Urban apartments	High rises
10	NYC/217/56/01	Urban apartments	High rises
11	NYC/215/56/01	Urban apartments	High rises
12	NYC/212/56/01	Urban apartments	High rises
13	NYC/211/56/01	Urban apartments	High rises
14	NYC/216/56/01	Urban apartments	High rises
15	NYC/218/56/01	Urban apartments	High rises
16	NYC/210/56/01	Urban apartments	High rises
17	NYC/213/56/01	Urban apartments	High rises
18	NYC/219/56/01	Urban apartments	High rises
19	WAS-006/34/01	Suburban - Cul de Sac - Some Trees	Single Family Home
20	WAS-023/34/01	Suburban almost rural with lots of trees	Single Family Home
21	WAS-023/48/01	Suburban almost rural with lots of trees	Single Family Home
22	WAS-003/27/01	Suburban	Single Family Home
23	WAS-003/35/01	Suburban	Single Family Home
24	WAS-311/34/01	Apartment Buildings, Single Family Homes	Apartment (High-Rise)
25	WAS-311/35/01	Apartment Buildings, Single Family Homes	Apartment (High-Rise)
26	WAS-311/36/01	Apartment Buildings, Single Family Homes	Apartment (High-Rise)
27	WAS-311/39/01	Apartment Buildings, Single Family Homes	Apartment (High-Rise)
28	WAS-311/48/01	Apartment Buildings, Single Family Homes	Apartment (High-Rise)
29	WAS-032/48/01	Suburban	Single Family Home
30	WAS-034/27/01	Metal Roof	Town House
31	WAS-034/35/01	Metal Roof	Town House
32	WAS-034/48/01	Metal Roof	Town House
33	WAS-038/34/01	Townhouse community Near B-W Parkway	Town House
34	WAS-038/34/01	Townhouse community Near B-W Parkway	Town House
35	WAS-038/36/01	Townhouse community Near B-W Parkway	Town House
36	WAS-047/48/01	Single Family homes. Small rolling hills	Single Family Home
37	WAS-049/34/01	Single Family homes. Mostly flat terrain. Flight path of BWI airport (landing path).	Single Family Home
38	WAS-049/39/01	Single Family homes. Mostly flat terrain. Flight path of BWI airport (landing path).	Single Family Home
39	WAS-051/35/01	Suburban	Single Family Home
40	WAS-063/34/01	Suburban Alexandria mix of single and two floor homes	Single Family Home
41	WAS-068/36/01	Residential	Single Family Home
42	WAS-075/35/01	Suburban	Single Family Home
43	WAS-075/36/01	Suburban	Single Family Home
44	WAS-075/39/01	Suburban	Single Family Home
45	WAS-080/35/01	Suburban hills and lots of trees	Town House
46	WAS-081/36/01	Suburban, Hilly Terrain, Trees	Single Family Home
47	WAS-082/35/01	Suburban Inside Beltway, very hilly	Single Family Home
48	WAS-083/36/01	Upscale Urban townhomes, Georgetown, Hilly	Town House
49	WAS-083/39/01	Upscale Urban townhomes, Georgetown, Hilly	Town House
50	WAS-086/36/01	Rural, Large separate lots	Single Family Home
51	WAS-086/48/01	Rural, Large separate lots	Single Family Home
52			
53			
54			
55			

	A	P	Q	R	S	T	U	V	W
1	Site Name	Antenna Location	Antenna height	Antenna Type	Antenna Orientation	Construction Type	Siding	Weather Conditions	Temperature
2	NYC/209/44/01	Bedroom	6	Double Bow-Tie	Optimal	Wood	Brick	Cloudy	50
3	NYC/202/44/01	Bedroom	6	Loop	Optimal	Wood	Brick	Cloudy	50
4	NYC/200/44/01	Bedroom	6	MegaWave	Optimal	Wood	Brick	Cloudy	50
5	NYC/208/44/01	Bedroom	6	Rabbits Ears	Optimal	Wood	Brick	Cloudy	50
6	NYC/205/44/01	Bedroom	6	Silver Sensor (V)	Optimal	Wood	Brick	Cloudy	50
7	NYC/206/44/01	Bedroom	6	Silver Sensor (H)	Optimal	Wood	Brick	Cloudy	50
8	NYC/204/44/01	Bedroom	6	Silver Sensor (H)	Optimal	Wood	Brick	Cloudy	50
9	NYC/207/44/01	Bedroom	6	Yagi	Optimal	Wood	Brick	Cloudy	50
10	NYC/217/56/01	Bedroom	6	Bow-Tie	Optimal	Wood	Brick	Cloudy	50
11	NYC/215/56/01	Bedroom	6	Double Bow-Tie	Optimal	Wood	Brick	Cloudy	50
12	NYC/212/56/01	Bedroom	6	Dual Silver Sensor	Optimal	Wood	Brick	Cloudy	50
13	NYC/211/56/01	Bedroom	6	Dual Silver Sensor	Optimal	Wood	Brick	Cloudy	50
14	NYC/216/56/01	Bedroom	6	Loop	Optimal	Wood	Brick	Cloudy	50
15	NYC/218/56/01	Bedroom	6	MegaWave	Optimal	Wood	Brick	Cloudy	50
16	NYC/210/56/01	Bedroom	6	Rabbit Ears	Optimal	Wood	Brick	Cloudy	50
17	NYC/213/56/01	Bedroom	6	Silver Sensor(H)	Optimal	Wood	Brick	Cloudy	50
18	NYC/219/56/01	Bedroom	6	Yagi	Optimal	Wood	Brick	Cloudy	50
19	WAS-006/34/01	outdoor	30	Log Periodic	Optimal	Wood	Concrete	Partly Cloudy	94
20	WAS-023/34/01	Living Room	6	Double Bow-Tie	Optimal	Brick	Brick	Sunny	74
21	WAS-023/48/01	Living Room	6	Double Bow-Tie	Optimal	Brick	Brick	Sunny	76
22	WAS-003/27/01	outdoor	30	Log Periodic	Optimal	Wood	Vinyl	Sunny	91
23	WAS-003/35/01	outdoor	30	Log Periodic	Optimal	Wood	Vinyl	Sunny	93
24	WAS-311/34/01	Living Room	6	Double Bow-Tie	Optimal	Wood	Brick	Cloudy	70
25	WAS-311/35/01	outdoor	30	Log Periodic	Optimal	Wood	Brick	Cloudy	70
26	WAS-311/36/01	outdoor	30	Log Periodic	Optimal	Wood	Brick	Cloudy	70
27	WAS-311/39/01	Living Room	6	Double Bow-Tie	Optimal	Wood	Brick	Cloudy	70
28	WAS-311/48/01	outdoor	30	Log Periodic	Optimal	Wood	Brick	Cloudy	70
29	WAS-032/48/01	Living Room	6	Double Bow-Tie	Optimal	Wood	Brick	Cloudy	86
30	WAS-034/27/01	Living Room	6	Double Bow-Tie	Optimal	Metal	Brick	Sunny	77
31	WAS-034/35/01	Living Room	6	Double Bow-Tie	Optimal	Metal	Brick	Partly Cloudy	81
32	WAS-034/48/01	Living Room	6	Double Bow-Tie	Optimal	Metal	Brick	Partly Sunny	82
33	WAS-038/34/01	Rec Room	6	Double Bow-Tie	Optimal	Wood	Aluminum	Sunny	70
34	WAS-038/34/01	outdoor	30	Log Periodic	Optimal	Wood	Aluminum	Sunny	75
35	WAS-038/36/01	Rec Room	6	Double Bow-Tie	Optimal	Wood	Aluminum	Sunny	70
36	WAS-047/48/01	Family Room	6	Double Bow-Tie	Optimal	Wood	Wood	Cloudy	70
37	WAS-049/34/01	Living Room	6	Double Bow-Tie	Optimal	Wood	Vinyl	Cloudy	70
38	WAS-049/39/01	Living Room	6	Double Bow-Tie	Optimal	Wood	Vinyl	Cloudy	70
39	WAS-051/35/01	outdoor	30	Log Periodic	Optimal	Brick	Brick	Sunny	83
40	WAS-063/34/01	Living Room	6	Double Bow-Tie	Optimal	Wood	Brick	Cloudy	75
41	WAS-068/36/01	outdoor	30	Log Periodic	Optimal	Wood	Brick	Cloudy	65
42	WAS-075/35/01	Living Room	6	Double Bow-Tie	Optimal	Wood	Vinyl	Cloudy	88
43	WAS-075/36/01	Living Room	6	Double Bow-Tie	Optimal	Wood	Vinyl	Partly Cloudy	85
44	WAS-075/39/01	Living Room	6	Double Bow-Tie	Optimal	Wood	Vinyl	Partly Cloudy	86
45	WAS-080/35/01	Living Room	6	Double Bow-Tie	Optimal	Brick	Aluminum	Cloudy	76
46	WAS-081/36/01	Living Room	6	Double Bow-Tie	Optimal	Concrete	Brick	Cloudy	71
47	WAS-082/35/01	Living Room	6	Double Bow-Tie	Optimal	Brick	Brick	Sunny	N/A
48	WAS-083/36/01	Living Room	6	Double Bow-Tie	Optimal	Brick	Brick	Cloudy	78
49	WAS-083/39/01	Living Room	6	Double Bow-Tie	Optimal	Brick	Brick	Cloudy	77
50	WAS-086/36/01	Living Room	6	Double Bow-Tie	Optimal	Wood	Wood	Sunny	80
51	WAS-086/48/01	outdoor	30	Log Periodic	Optimal	Wood	Wood	Sunny	90
52									
53									
54									
55									

	A	X	Y	Z	AA	AB
	Data Captured					
1	Site Name	by	Data Format	AGC	SAW	Original data capture filename
2	NYC/209/44/01	ATTC	12 bits as 2-Byte Signed Integer	n	8Mhz	NYC_200_44_10272000_DBT1
3	NYC/202/44/01	ATTC	12 bits as 2-Byte Signed Integer	n	8Mhz	NYC_200_44_10272000_LOOP1
4	NYC/200/44/01	ATTC	12 bits as 2-Byte Signed Integer	n	8Mhz	NYC_200_44_10272000_MEGA1
5	NYC/208/44/01	ATTC	12 bits as 2-Byte Signed Integer	n	8Mhz	NYC_200_44_10272000_RAB1
6	NYC/205/44/01	ATTC	12 bits as 2-Byte Signed Integer	n	8Mhz	NYC_200_44_10272000_SSEN1
7	NYC/206/44/01	ATTC	12 bits as 2-Byte Signed Integer	n	8Mhz	NYC_200_44_10272000_SSEN2
8	NYC/204/44/01	ATTC	12 bits as 2-Byte Signed Integer	n	8Mhz	NYC_200_44_10272000_SSEN3
9	NYC/207/44/01	ATTC	12 bits as 2-Byte Signed Integer	n	8Mhz	NYC_200_44_10272000_YAG1
10	NYC/217/56/01	ATTC	12 bits as 2-Byte Signed Integer	n	8Mhz	NYC_200_56_10272000_BWT1
11	NYC/215/56/01	ATTC	12 bits as 2-Byte Signed Integer	n	8Mhz	NYC_200_56_10272000_DBT2
12	NYC/210/56/01	ATTC	12 bits as 2-Byte Signed Integer	n	8Mhz	NYC_200_56_10272000_DSEN1
13	NYC/211/56/01	ATTC	12 bits as 2-Byte Signed Integer	n	8Mhz	NYC_200_56_10272000_DSEN2
14	NYC/216/56/01	ATTC	12 bits as 2-Byte Signed Integer	n	8Mhz	NYC_200_56_10272000_LOOP1
15	NYC/218/56/01	ATTC	12 bits as 2-Byte Signed Integer	n	8Mhz	NYC_200_56_10272000_MEGA1
16	NYC/210/56/01	ATTC	12 bits as 2-Byte Signed Integer	n	8Mhz	NYC_200_56_10272000_RAB1
17	NYC/213/56/01	ATTC	12 bits as 2-Byte Signed Integer	n	8Mhz	NYC_200_56_10272000_SSEN1
18	NYC/219/56/01	ATTC	12 bits as 2-Byte Signed Integer	n	8Mhz	NYC_200_56_10272000_YAG1
19	WAS-006/34/01	ATTC/MSTV	12 bits as 2-Byte Signed Integer	n	8Mhz	WAS_06_34_06092000_REF
20	WAS-023/34/01	ATTC/MSTV	12 bits as 2-Byte Signed Integer	n	8Mhz	WAS_23_34_06072000_OPT
21	WAS-023/48/01	ATTC/MSTV	12 bits as 2-Byte Signed Integer	n	8Mhz	WAS_23_48_06072000_OPT
22	WAS-003/27/01	ATTC/MSTV	12 bits as 2-Byte Signed Integer	n	8Mhz	WAS_3_27_06022000_REF
23	WAS-003/35/01	ATTC/MSTV	12 bits as 2-Byte Signed Integer	n	8Mhz	WAS_3_35_06022000_REF
24	WAS-311/34/01	ATTC/MSTV	12 bits as 2-Byte Signed Integer	n	8Mhz	WAS_311_34_06052000_OPT
25	WAS-311/35/01	ATTC/MSTV	12 bits as 2-Byte Signed Integer	n	8Mhz	WAS_311_35_06052000_REF
26	WAS-311/36/01	ATTC/MSTV	12 bits as 2-Byte Signed Integer	n	8Mhz	WAS_311_36_06052000_REF
27	WAS-311/39/01	ATTC/MSTV	12 bits as 2-Byte Signed Integer	n	8Mhz	WAS_311_39_06052000_OPT
28	WAS-311/48/01	ATTC/MSTV	12 bits as 2-Byte Signed Integer	n	8Mhz	WAS_311_48_06052000_REF
29	WAS-032/48/01	ATTC/MSTV	12 bits as 2-Byte Signed Integer	n	8Mhz	WAS_32_48_06012000_OPT
30	WAS-034/27/01	ATTC/MSTV	12 bits as 2-Byte Signed Integer	n	8Mhz	WAS_34_27_06082000_OPT
31	WAS-034/35/01	ATTC/MSTV	12 bits as 2-Byte Signed Integer	n	8Mhz	WAS_34_35_06082000_OPT
32	WAS-034/48/01	ATTC/MSTV	12 bits as 2-Byte Signed Integer	n	8Mhz	WAS_34_48_06082000_OPT
33	WAS-038/34/01	ATTC/MSTV	12 bits as 2-Byte Signed Integer	n	8Mhz	WAS_38_34_05312000_OPT
34	WAS-038/34/01	ATTC/MSTV	12 bits as 2-Byte Signed Integer	n	8Mhz	WAS_38_34_05312000_REF
35	WAS-038/36/01	ATTC/MSTV	12 bits as 2-Byte Signed Integer	n	8Mhz	WAS_38_36_05312000_OPT
36	WAS-047/48/01	ATTC/MSTV	12 bits as 2-Byte Signed Integer	n	8Mhz	WAS_47_48_06132000_OPT
37	WAS-049/34/01	ATTC/MSTV	12 bits as 2-Byte Signed Integer	n	8Mhz	WAS_49_34_06142000_OPT
38	WAS-049/39/01	ATTC/MSTV	12 bits as 2-Byte Signed Integer	n	8Mhz	WAS_49_39_06142000_OPT
39	WAS-051/35/01	ATTC/MSTV	12 bits as 2-Byte Signed Integer	n	8Mhz	WAS_51_35_05242000_REF
40	WAS-063/34/01	ATTC/MSTV	12 bits as 2-Byte Signed Integer	n	8Mhz	WAS_63_34_06212000_OPT
41	WAS-068/36/01	ATTC/MSTV	12 bits as 2-Byte Signed Integer	n	8Mhz	WAS_68_36_05232000_REF
42	WAS-075/35/01	ATTC/MSTV	12 bits as 2-Byte Signed Integer	n	8Mhz	WAS_75_35_06162000_OPT
43	WAS-075/36/01	ATTC/MSTV	12 bits as 2-Byte Signed Integer	n	8Mhz	WAS_75_36_06162000_OPT
44	WAS-075/39/01	ATTC/MSTV	12 bits as 2-Byte Signed Integer	n	8Mhz	WAS_75_39_06162000_OPT
45	WAS-080/35/01	ATTC/MSTV	12 bits as 2-Byte Signed Integer	n	8Mhz	WAS_80_35_06152000_OPT
46	WAS-081/36/01	ATTC/MSTV	12 bits as 2-Byte Signed Integer	n	8Mhz	WAS_81_36_06192000_OPT
47	WAS-082/35/01	ATTC/MSTV	12 bits as 2-Byte Signed Integer	n	8Mhz	WAS_82_35_06202000_OPT
48	WAS-083/36/01	ATTC/MSTV	12 bits as 2-Byte Signed Integer	n	8Mhz	WAS_83_36_06222000_OPT
49	WAS-083/39/01	ATTC/MSTV	12 bits as 2-Byte Signed Integer	n	8Mhz	WAS_83_39_06222000_OPT
50	WAS-086/36/01	ATTC/MSTV	12 bits as 2-Byte Signed Integer	n	8Mhz	WAS_86_36_07122000_OPT
51	WAS-086/48/01	ATTC/MSTV	12 bits as 2-Byte Signed Integer	n	8Mhz	WAS_86_48_07122000_REF
52						
53						
54						
55						

	A	AC
1	Site Name	Demodulated by current receiver
2	NYC/209/44/01	Demod. by latest prototype only
3	NYC/202/44/01	No/intermittent demod by pprototype only
4	NYC/200/44/01	Demod. by latest prototype only*
5	NYC/208/44/01	Demod. by latest protypre only*
6	NYC/205/44/01	Demod by latest prototype only
7	NYC/206/44/01	No/intermittent demod by pprototype only
8	NYC/204/44/01	No
9	NYC/207/44/01	No/intermittent demod by pprototype only
10	NYC/217/56/01	Demod. by latest prototype only
11	NYC/215/56/01	Demod. by latest prototype only
12	NYC/212/56/01	Demod. by latest prototype only
13	NYC/211/56/01	Demod. by latest prototype only
14	NYC/216/56/01	Demod. by latest prototype only
15	NYC/218/56/01	Demod. by latest prototype only
16	NYC/210/56/01	Demod. by latest prototype only
17	NYC/213/56/01	Demod. by latest prototype only
18	NYC/219/56/01	Demod. by latest prototype only
19	WAS-006/34/01	No
20	WAS-023/34/01	Demod by some receivers
21	WAS-023/48/01	No
22	WAS-003/27/01	Demod by latest prototype only
23	WAS-003/35/01	Demod. by some recievers*
24	WAS-311/34/01	No
25	WAS-311/35/01	Yes. All receivers*
26	WAS-311/36/01	Demod. by latest prototype only
27	WAS-311/39/01	No
28	WAS-311/48/01	Yes All receivers*
29	WAS-032/48/01	No
30	WAS-034/27/01	Yes. All receivers
31	WAS-034/35/01	No
32	WAS-034/48/01	No
33	WAS-038/34/01	No
34	WAS-038/34/01	No
35	WAS-038/36/01	Demod by some recievers
36	WAS-047/48/01	Demod by some receivers
37	WAS-049/34/01	No
38	WAS-049/39/01	No
39	WAS-051/35/01	No
40	WAS-063/34/01	Demod by latest prototype only*
41	WAS-068/36/01	No
42	WAS-075/35/01	No
43	WAS-075/36/01	No
44	WAS-075/39/01	Demod by latest prototype only
45	WAS-080/35/01	No
46	WAS-081/36/01	Yes All receivers*
47	WAS-082/35/01	Demod by latest prototype only
48	WAS-083/36/01	No
49	WAS-083/39/01	No
50	WAS-086/36/01	No
51	WAS-086/48/01	No
52		
53		* One or two hits due to symbols drops
54		or other factors
55		

	A	AD	AE
1	Site Name	Capture comments	Single dominant echo
2	NYC/209/44/01		
3	NYC/202/44/01		
4	NYC/200/44/01		
5	NYC/208/44/01		
6	NYC/205/44/01		
7	NYC/206/44/01		
8	NYC/204/44/01		
9	NYC/207/44/01		
10	NYC/217/56/01		
11	NYC/215/56/01		
12	NYC/212/56/01		
13	NYC/211/56/01		
14	NYC/216/56/01		
15	NYC/218/56/01		
16	NYC/210/56/01		
17	NYC/213/56/01		
18	NYC/219/56/01		
19	WAS-006/34/01		y
20	WAS-023/34/01		
21	WAS-023/48/01		
22	WAS-003/27/01		
23	WAS-003/35/01		
24	WAS-311/34/01		
25	WAS-311/35/01		
26	WAS-311/36/01	-17 dBu V/m Pro Demod - constant SER 12860 Many aircraft above and in front of location	
27	WAS-311/39/01	Signal path in air traffic flight path - frequent fades and flutter; -54.5 dBu V/m	
28	WAS-311/48/01	pro demod would not lock during capture. Possible hits	
29	WAS-032/48/01		
30	WAS-034/27/01		
31	WAS-034/35/01		
32	WAS-034/48/01		
33	WAS-038/34/01		
34	WAS-038/34/01		
35	WAS-038/36/01	Pro demod would not lock.	
36	WAS-047/48/01		
37	WAS-049/34/01		
38	WAS-049/39/01		
39	WAS-051/35/01		
40	WAS-063/34/01	Very Poor Signal Level	
41	WAS-068/36/01		
42	WAS-075/35/01	Wind gusts of up to 15 mph	
43	WAS-075/36/01	Wind comes and goes. Very dynamic signal. Attempted capture several times	
44	WAS-075/39/01	Windy	
45	WAS-080/35/01		
46	WAS-081/36/01		
47	WAS-082/35/01		
48	WAS-083/36/01		
49	WAS-083/39/01		
50	WAS-086/36/01		
51	WAS-086/48/01		
52			
53			
54			
55			

	A	AF	AG	AH	AI	AJ	AK	AL	AM	AN	AO
		Close-in echoe(s)	Multiple echoes	Deep notche(s)	Wide notche(s)	Flat fading	Band- edge distortion	Pilot notch	Static	Slow dynamic	Moderate dynamics
1	Site Name										
2	NYC/209/44/01	y	y			y				y	
3	NYC/202/44/01	y	y			y		y		y	
4	NYC/200/44/01		y			y				y	
5	NYC/208/44/01		y		y	y		y		y	
6	NYC/205/44/01		y			y		y		y	
7	NYC/206/44/01	y	y			y				y	
8	NYC/204/44/01	y	y			y				y	
9	NYC/207/44/01		y			y				y	
10	NYC/217/56/01		y			y				y	
11	NYC/215/56/01		y			y				y	
12	NYC/212/56/01		y			y				y	
13	NYC/211/56/01		y			y				y	
14	NYC/216/56/01		y			y				y	
15	NYC/218/56/01		y			y				y	
16	NYC/210/56/01		y			y				y	
17	NYC/213/56/01		y			y				y	
18	NYC/219/56/01		y			y				y	
19	WAS-006/34/01								y		
20	WAS-023/34/01		y	y	y		y				y
21	WAS-023/48/01		y	y	y						y
22	WAS-003/27/01		y	y				y		y	
23	WAS-003/35/01										
24	WAS-311/34/01		y			y					
25	WAS-311/35/01		y			y				y	
26	WAS-311/36/01		y	y	y				y	y	
27	WAS-311/39/01		y			y				y	
28	WAS-311/48/01		y	y	y						
29	WAS-032/48/01		y	y	y					y	
30	WAS-034/27/01	y				y				y	
31	WAS-034/35/01					y		y			
32	WAS-034/48/01		y								
33	WAS-038/34/01		y	y							
34	WAS-038/34/01										
35	WAS-038/36/01										
36	WAS-047/48/01		y			y				y	
37	WAS-049/34/01		y	y		y	y			y	
38	WAS-049/39/01		y	y						y	
39	WAS-051/35/01					y			y		
40	WAS-063/34/01					y			y		
41	WAS-068/36/01					y			y		
42	WAS-075/35/01		y	y	y		y				y
43	WAS-075/36/01		y	y	y		y	y			
44	WAS-075/39/01		y	y	y		y				y
45	WAS-080/35/01								y		
46	WAS-081/36/01										
47	WAS-082/35/01		y			y	y		y		
48	WAS-083/36/01		y			y	y	y			
49	WAS-083/39/01		y			y				y	
50	WAS-086/36/01										
51	WAS-086/48/01										
52											
53											
54											
55											

	A	AP	AQ	AR	AS
1	Site Name	Fast dynamic	Irregular dynamic	Regular dynamic	In-band interference
2	NYC/209/44/01				weak lower
3	NYC/202/44/01				weak lower
4	NYC/200/44/01				none
5	NYC/208/44/01				weak lower
6	NYC/205/44/01				weak lower
7	NYC/206/44/01				weak lower
8	NYC/204/44/01				weak lower
9	NYC/207/44/01				weak lower
10	NYC/217/56/01				none
11	NYC/215/56/01				none
12	NYC/212/56/01				none
13	NYC/211/56/01			y	weak lower
14	NYC/216/56/01			y	weak lower
15	NYC/218/56/01			y	none
16	NYC/210/56/01				weak lower
17	NYC/213/56/01			y	none
18	NYC/219/56/01			y	none
19	WAS-006/34/01				moderate upper
20	WAS-023/34/01		y		upper adjacent
21	WAS-023/48/01		y		none
22	WAS-003/27/01			y	inband l. adj. Audio
23	WAS-003/35/01				strong upper & lower
24	WAS-311/34/01				inband upper & lower
25	WAS-311/35/01				moderate lower & strong upper adj
26	WAS-311/36/01			y	inbandlower
27	WAS-311/39/01				none
28	WAS-311/48/01				none
29	WAS-032/48/01				none
30	WAS-034/27/01				strong lower
31	WAS-034/35/01				weak lower & strong upper
32	WAS-034/48/01	y			none
33	WAS-038/34/01				Inband RFI
34	WAS-038/34/01				none
35	WAS-038/36/01				Inband RFI
36	WAS-047/48/01			y	none
37	WAS-049/34/01				none
38	WAS-049/39/01				strong lower
39	WAS-051/35/01				Strong Upper& lower adj.
40	WAS-063/34/01				upper adj. visual
41	WAS-068/36/01				lower adjacent ch.
42	WAS-075/35/01		y		Upper & lower adj.
43	WAS-075/36/01	y	y		Inband RFI
44	WAS-075/39/01			y	none
45	WAS-080/35/01				strong upper and lower adj
46	WAS-081/36/01				Inband RFI
47	WAS-082/35/01				Strong Upper Adj.
48	WAS-083/36/01				moderate lower adj
49	WAS-083/39/01				none
50	WAS-086/36/01				Inband RFI
51	WAS-086/48/01				weak lower adj
52					
53					
54					
55					

Annex B: Impulse Response Analysis

1. SCOPE

This annex provides a detailed impulse response analysis for a selection of captured field ensembles. The field ensembles were selected to give examples of the richness of multipath conditions in the field. The ensembles, however, do not necessarily represent limits on field conditions that may be experienced.

2. CHANNEL IMPULSE RESPONSE ANALYSIS

2.1 Data Analysis Using Real Versus Complex Demodulators/Equalizers

The channel impulse response analyses in this Annex were obtained by performing a cross correlation of the PN511 sequence in the captured signal's field sync with a PN511 reference signal. Some comments may be helpful on the use of a real only demodulator/equalizer versus a complex demodulator/equalizer. These comments are not a recommendation of one receiver architecture versus another but are intended to provide information regarding analyzing channel impulse response via cross correlation.

By way of example, in a real-only equalizer/demodulator, the magnitude of the echo is dependent upon the carrier phase relationship between signals received from the echo and dominant paths (assuming receiver carrier recovery is predominantly influenced by the dominant path). So, if one takes the case of an echo that is in phase quadrature with the main path, the output of a real demodulator will, theoretically, be zero for a static echo and will be maximum only when the relative phase of the carrier reference is zero or 180 degrees. So, there exists a chance of losing cross correlation information with a real-only demodulator/equalizer. With a complex demodulator, the correct magnitude of the echo can be obtained from the I and Q output data under all relative phase conditions.

Also, the correlation power of the echo path will naturally fall off as the delay limits of the PN sequence are approached, as mentioned above.

2.2 Channel Estimations Using 511 Pseudo-Random Sequence

Channel estimations may be obtained from RF captures using the 511 pseudo-random number sequence located in the 8-VSB field sync. The field sync and its PN511 sequence is repeated every 24.2 milliseconds. Consequently, over 1000 channel estimations may be computed during each 25-second capture.

The channel estimation is calculated using a symbol-by-symbol cross-correlation of the recovered 8-VSB symbol stream. The PN511 symbol sequence is located within the synchronization segment of the captured RF signal. This recovered PN511 sequence is correlated with three ideal PN511 sequences, as illustrated in Figure B.1. As the recovered PN511 sequence is incremented across the ideal sequences, the main path and echoes are revealed in the results of the correlation.

**8 VSB Field Sync PN511 Sequence
recovered from DTV signal**

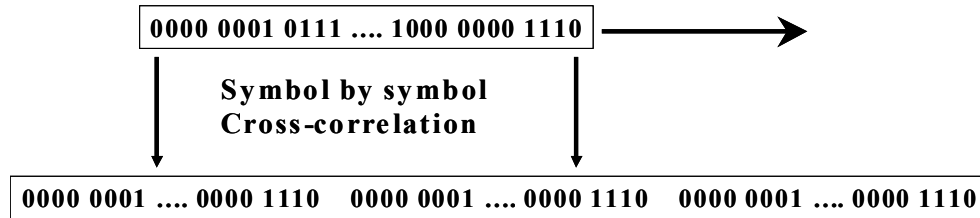

Three PN511 Sequences (Ideal)

Figure B.1 Method of channel estimation using the PN511 pseudo-random number sequence in the 8-VSB field sync involves a cross correlation with three ideal PN511 sequences.

Figure B.2 illustrates the correlation of an ideal 8-VSB signal. A single response is observed at zero microseconds. Otherwise, there is no correlation from $-23.69 \mu\text{s}$ to $+23.69 \mu\text{s}$ (± 255 symbols).

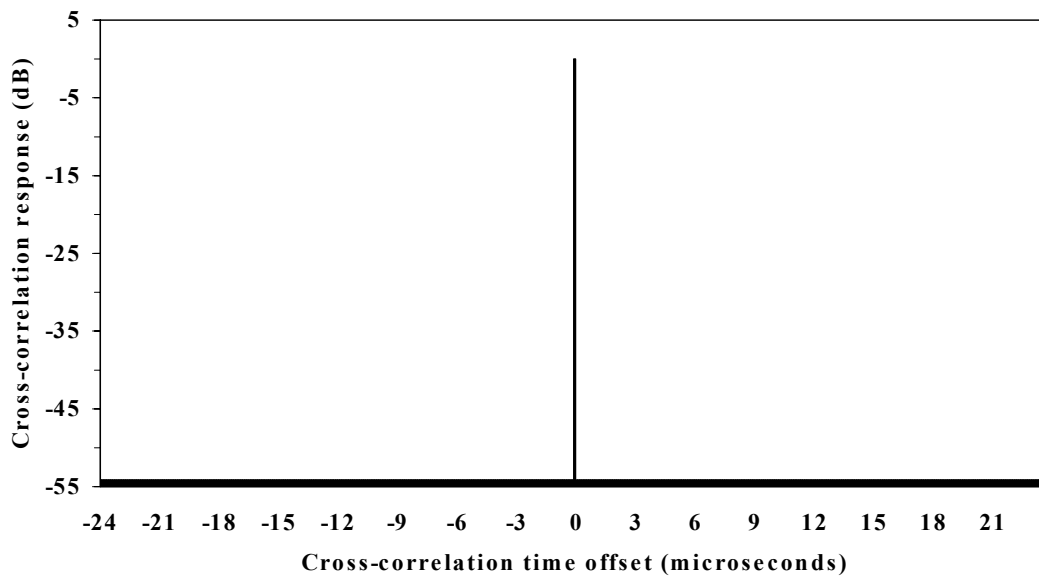

Figure B.2 Cross-correlation of an ideal 8-VSB PN511 sequence showing a single main path at zero microseconds.

In contrast, Figure B.3 shows the channel estimation for a single 10 μs echo captured in the laboratory with a power 6 dB below the main path. In addition to the main path at zero microseconds, the echo is observed at 10 μs . However, the echo appears to have a power lower than the main path by more than 6 dB.

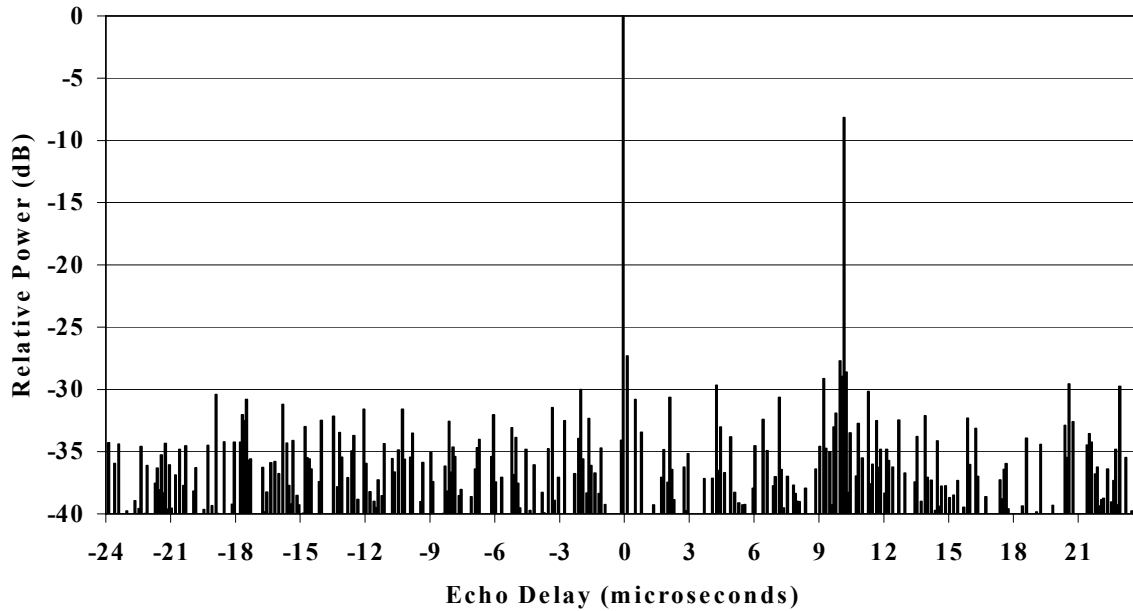

Figure B.3 Channel estimation of an 8-VSB signal capture in the laboratory in the presence of a 10 μs echo that is 6 dB lower in power than the main path.

The apparent decrease in echo power is the result of a correlation with only part of the PN511 sequence of the echo. As the delay of the echo moves away from either side of zero, that portion of the echo PN511 sequence included in the correlation diminishes. Consequently, the apparent power in the echo diminishes. In order to obtain the true echo power, the apparent power must be compensated. Figure B.4 illustrates the compensation factor required to obtain the actual echo power. In the example shown in Figure B.3, the 10 μs echo is actually 2 dB higher than the echo power measured by the cross-correlation.

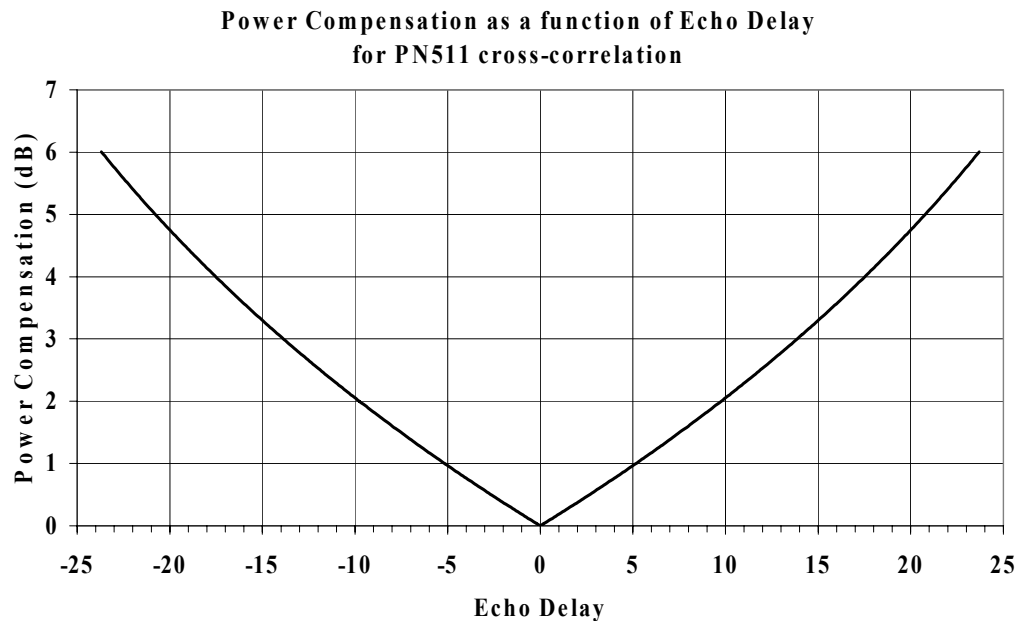

Figure B.4 Power compensation function required to obtain the actual echo power from channel estimations using the 8-VSB PN511 sequence.

2.3 Doppler Frequency Estimate

2.3.1 Comments on Doppler Analysis

When one considers evaluating multipath echoes with Doppler in an ATSC receiver (or other digital receiver), it should be remembered that the absolute transmit carrier frequency or phase is unknown because there is no direct carrier reference available in the receiver, as there would be, for example, in a radar system. The radar receiver has the advantage of receiving a direct carrier reference from the transmitter. So, at the radar receiver, it can be discerned which targets (echoes) are moving.

In the case of a DTV receiver, one has no knowledge of the absolute transmit frequency and phase. A relative carrier reference is reconstructed in the receiver that could be the vector sum of the individual multipath components, or perhaps just the dominant path, depending on how carrier recovery is implemented. For example, when it is inferred that a 10 μs post echo has a Doppler rate of say, 3 Hz, the 10 μs echo could, in fact, be perfectly stationary while the dominant path is the one with the Doppler component. One can only speak of “relative” Doppler

shifts between the multipath signals and cannot determine for certain the absolute rates of the individual components.

As another example, if a pre-echo is present (not the dominant path signal), it is clear that the dominant path signal is not coming directly from the transmitter site, but is a reflection, as would be any post echo. If the “pre-echo” in such a case were the direct path signal from the transmitter, one would expect it to exhibit very little Doppler (except, perhaps, for tower sway). Consequently the receiver designer should not assume that the dominant signal is stationary in frequency or phase.

2.3.2 Methodology for Doppler Frequency Estimate

Doppler frequencies were computed by observing the amplitude of the real part of the echo from the impulse response of the channel. Since the echo under consideration is isolated (not combined with any other echo), it is similar to observing the real part of a complex phasor over time. The real part of a phasor goes to minimum value at 180 degrees and 360 degrees, and, therefore, has two minimums (or maximums) in a single cycle. By calculating the reciprocal of the time between two minimums of the amplitude of the real part of the echo, the Doppler frequency at which the echo is rotating is obtained. The computation of Doppler frequency has been verified by simulating a synthetic channel with a software modulator and comparing the echo amplitude and Doppler frequency at multiple locations.

3. ANALYSIS OF RF CAPTURED DTV SIGNAL

3.1 Captured Channel WAS-105/51/01¹⁴

Figure B.5 illustrates the maximum main path power and echo power observed at any given instance within the outdoor signal capture WAS-105/51/01. The signal was recorded with a 6-foot dipole antenna in presence of pedestrian traffic. The antenna direction was not optimized for this capture. Although it appears that there is a significant spread in energy around the main path, the multipath conditions remain rather mild, as it was reported that the channel was demodulated by receivers of different generations.

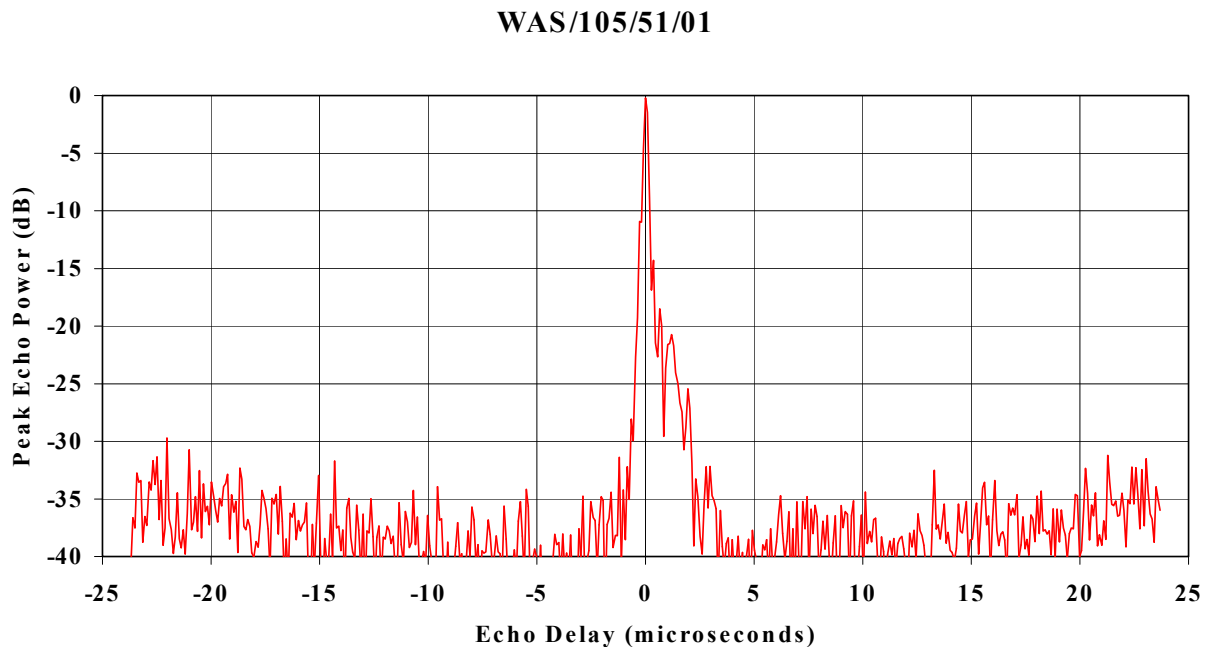

Figure B.5 Peak echo power as a function of echo delay observed for the duration of the RF capture at site WAS-105/51/01.

¹⁴ Although interesting from the multipath point of view, this channel has not been included in the recommended set of field ensembles, as it has been determined that the channel may be affected by capture equipment artifacts.

Figure B.6 illustrates the main power in addition to the echo power for the three greatest “echoes” (+93 ns, -93 ns, and +186 ns) during the RF signal capture WAS-105/51/01, showing the dynamic nature around the main path.

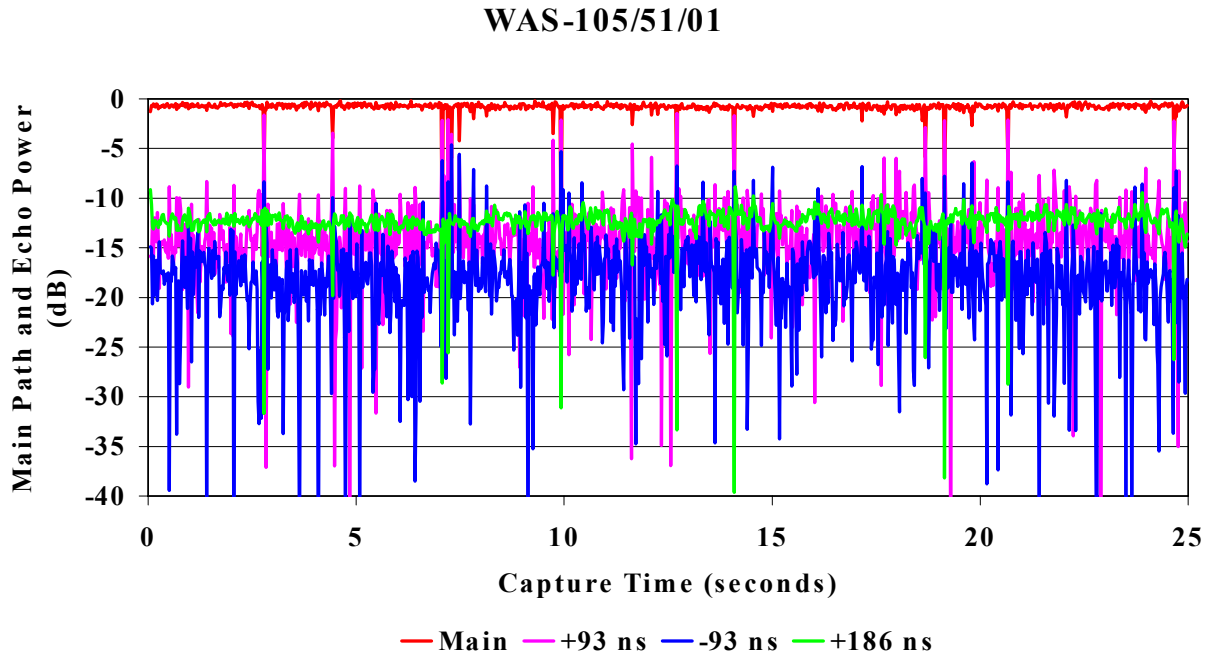

Figure B.6 Power of the main path in addition to the greatest “echoes” shows considerable variation over the duration of the RF capture for site WAS-105/51/01.

Figure B.7 demonstrates that it is likely that the main path signal itself is dynamic. This figure illustrates the total energy of the main path plus six adjacent “echoes” (± 93 ns, ± 186 ns, and ± 279 ns). Note that, even though the main path and the adjacent echoes vary considerably, the total power fluctuation is less than 1 dB.

WAS-105/51/01

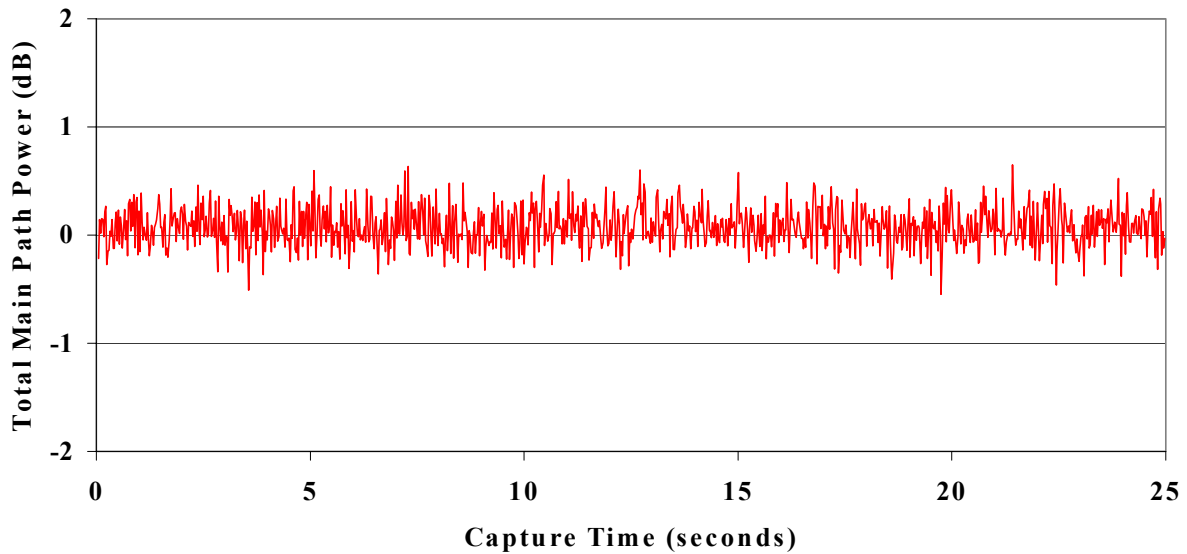

Figure B.7 Total power of the main path and ± 3 “echoes” about the main path illustrating the power is constant even though the main path is dynamic.

3.2 Captured Channel WAS-032/39/01 (Indoor)

Figure B.8 shows the maximum echo powers during the indoor RF signal capture for site WAS-032/39/01. In addition to the spread of energy localized around the main path, the impulse response clearly shows the presence of a post echo around 11 μs with an amplitude relative to the main path of -7 dB maximum.

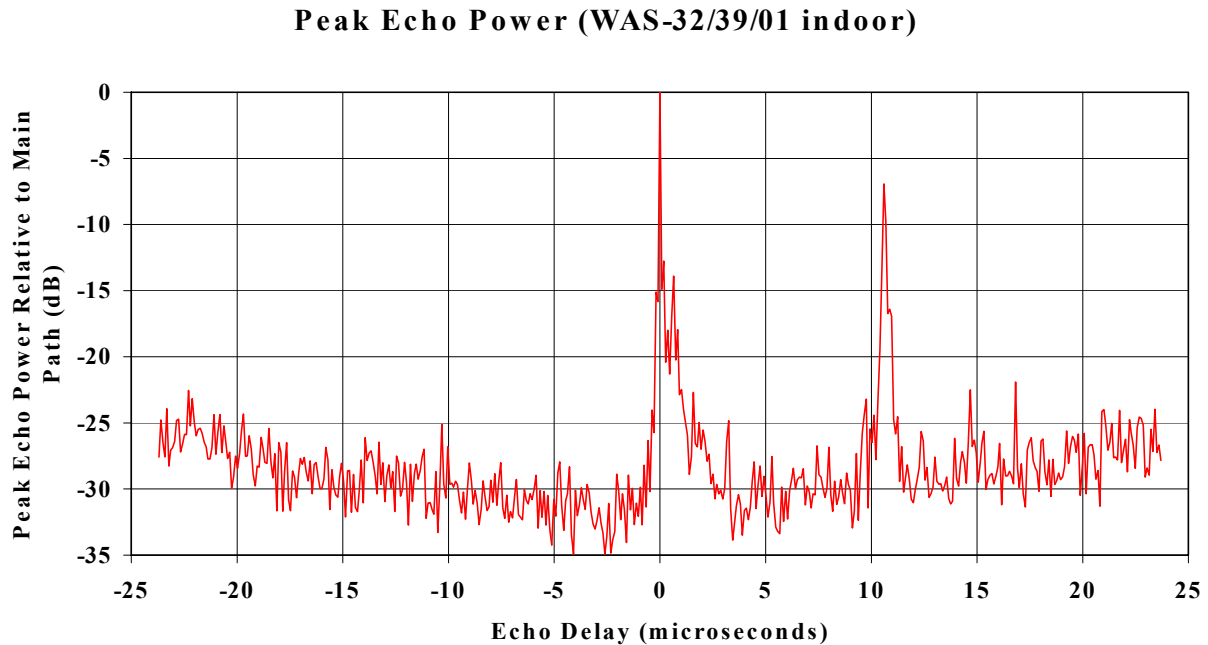

Figure B.8 Peak echo power as a function of echo delay observed for the duration of the RF capture at indoor site WAS-32/39/01.

Figure B.9 shows the magnitude of the post-echo located at +11 μs echo relative to the main path during the start of the capture. This echo is dynamic. The dynamic nature of the echo is interpreted as induced by a Doppler frequency shift with a frequency around 75 Hz (one cycle is completed in approximately 13 ms). For comparison, a line showing the amplitude of the main path is added to the plot.

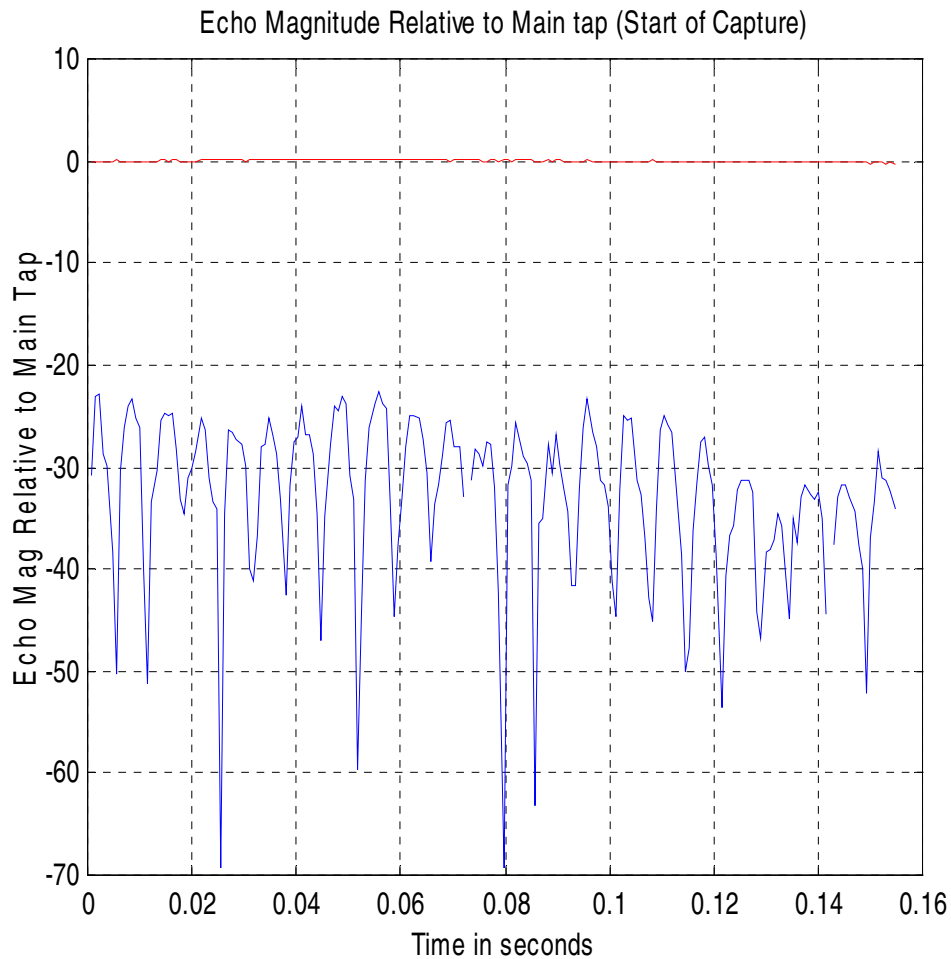

Figure B.9 The 11 μs echo magnitude at the beginning of the capture at indoor site WAS-32/39/01. Doppler frequency is 75 Hz.

Figure B.10 shows the magnitude of the 11 μs echo relative to the main path at around 6.7 seconds from the beginning of the capture. We notice that the echo strength is now 15 dB higher than before. The maximum of the echo reaches about -9 dB, which confirms the results furnished in Figure B.8. Notice that the Doppler frequency is significantly lower. The cycle time is now around 0.06 seconds, which indicates a Doppler frequency of 17 Hz.

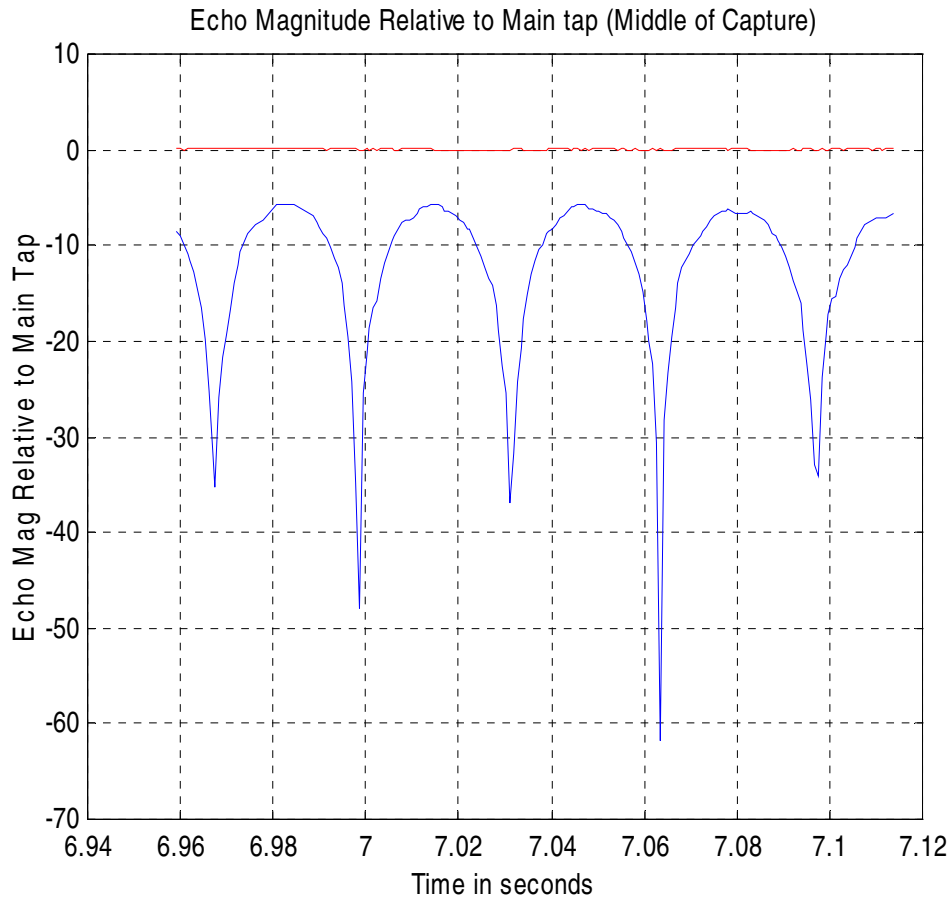

Figure B.10 The 11 μs echo magnitude 6.9 seconds into the capture at indoor site WAS-32/39/01. Doppler frequency is 17 Hz.

3.3 Captured Channel WAS-049/36/01

Figure B.11 shows the maximum echo power over the entire RF signal capture period. Note that there are equally spaced pre- and post-echoes, as would be expected for the “bobbing channel” (the dominant path swapping between main and post-echo positions). A channel estimate at the beginning of this capture shows that there is a distinct main path and one or more close in echoes. The post echo of principal interest is $1.75\ \mu\text{s}$ from the main path and has a rotating phase, as illustrated in the subsequent Figures B.12 through B.18.

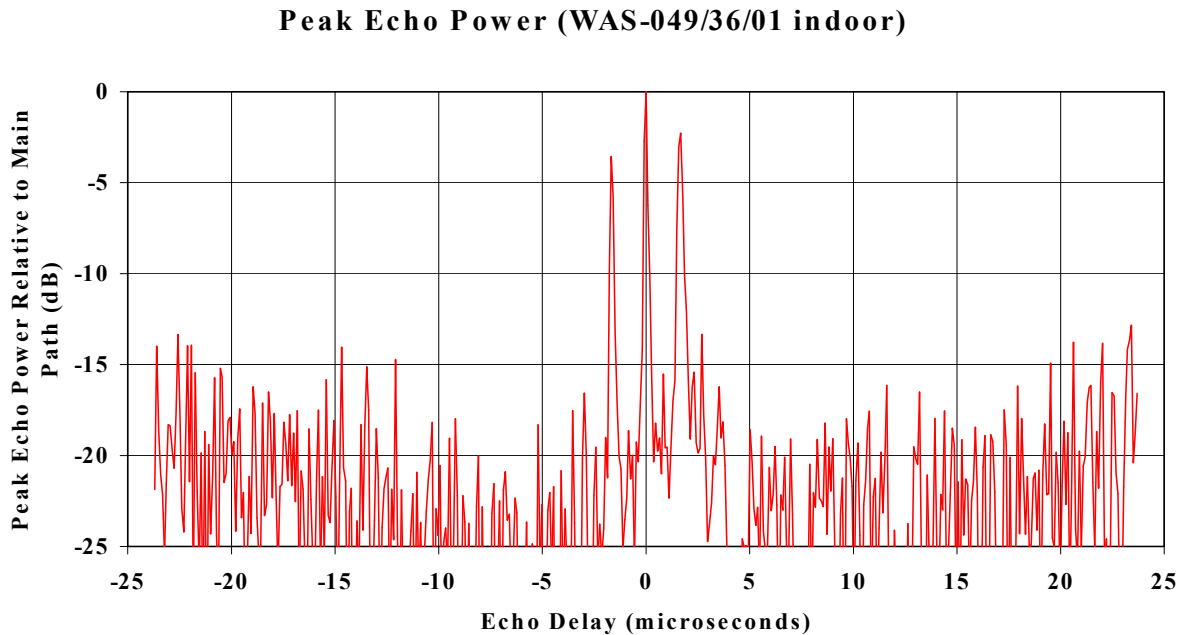

Figure B.11 Peak echo power as a function of echo delay observed for the duration of the RF capture at indoor site WAS-49/36/01. The evenly spaced echoes peaked at $\pm 1.67\ \mu\text{s}$ indicate that the main path and the echo alternate—a “bobbing” channel.

Figure B.12 shows the magnitude of the 1.75 μs echo relative to the main path over a period of about 0.16 seconds at the beginning of the capture. Notice that the main path amplitude is constant, whereas the echo has variable amplitude. The cycle time for this echo at this time is around 25 ms, which gives a Doppler frequency of about 40 Hz. The echo magnitude is around -15 dB relative to the main path.

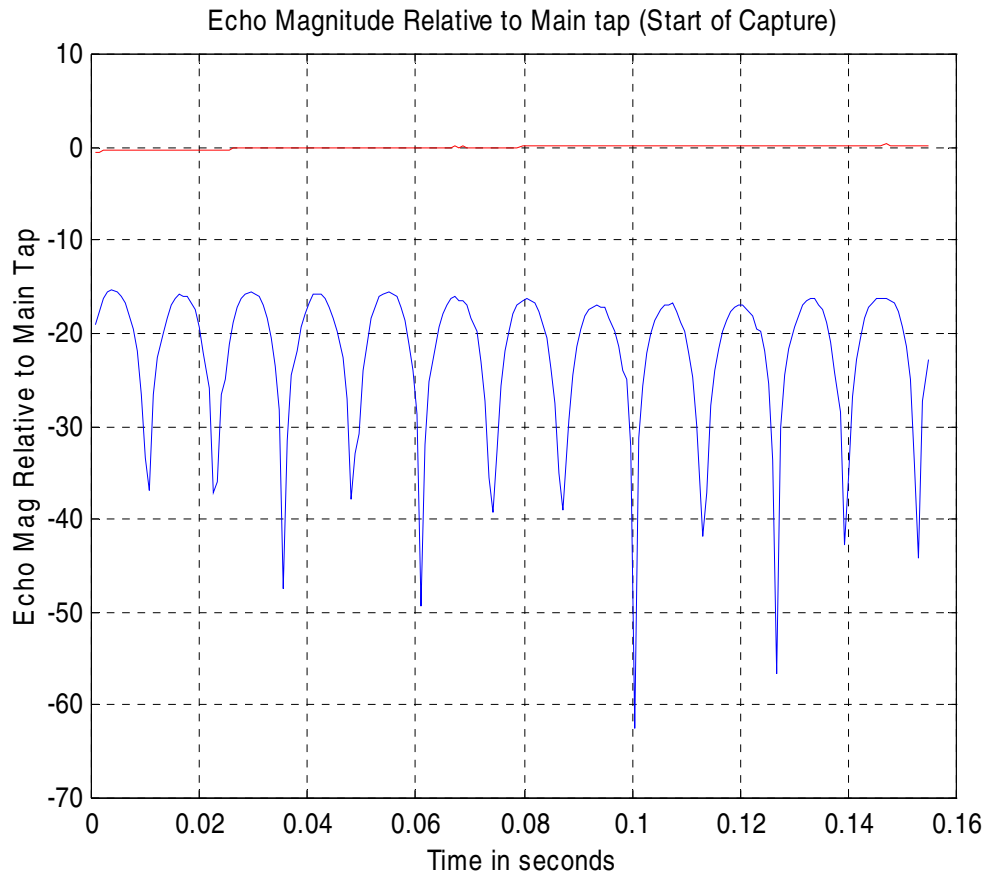

Figure B.12 Echo Magnitude for the 1.75 μs echo relative to the main path at the beginning of the capture at indoor site WAS-49/36/01. The echo magnitude is -15 dB relative to the main path. The Doppler frequency is 40 Hz.

Figure B.13 shows the magnitude of the 1.75 μs echo relative to the main path, 3 seconds into the capture. Notice that the main path amplitude is constant, whereas the echo has variable amplitude due to the Doppler phase rotation. The cycle time for this echo at this time is around 59 ms, which gives a Doppler frequency of about 17 Hz. The echo magnitude is about -5 dB relative to the main path.

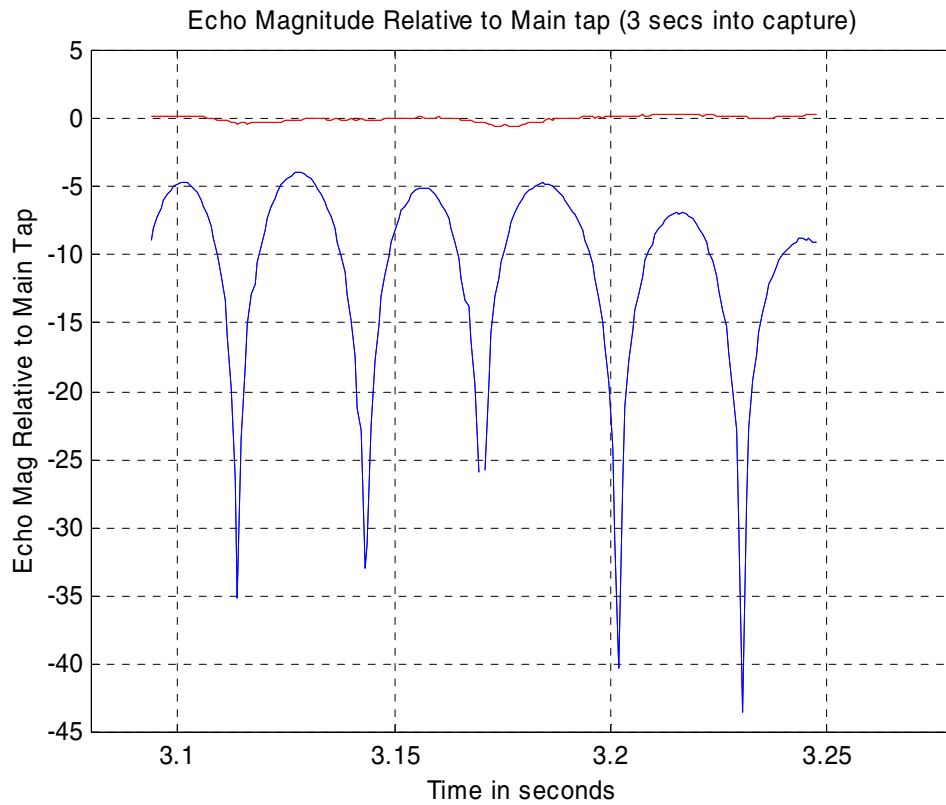

Figure B.13 Echo magnitude for the 1.75 μs echo relative to the main path, 3 seconds into the capture at indoor site WAS-49/36/01. The echo magnitude is -5 dB relative to the main path and has a Doppler frequency of 17 Hz.

Figure B.14 shows the magnitude of the 1.75 μs echo relative to the main path, 7.5 seconds into the capture. Notice that the main path amplitude is constant, whereas the echo has variable amplitude due to the Doppler phase rotation. The cycle time for this echo, at this time, is around 11.5 ms, which gives a Doppler frequency of about 80 Hz. The echo magnitude is about -25 dB to -15 dB relative to the main path.

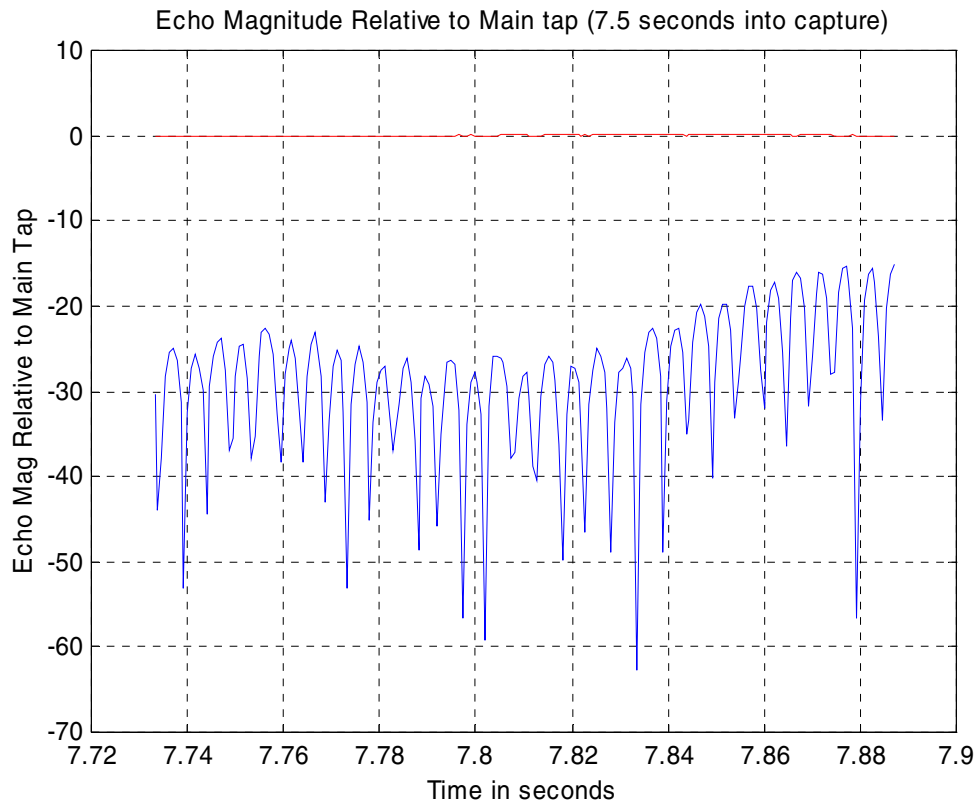

Figure B.14 Echo magnitude for the 1.75 μs echo relative to the main path, 7.5 seconds into the capture at indoor site WAS-49/36/01. The echo magnitude is -25 dB to -15 dB relative to the main path and has a Doppler frequency of 80Hz.

Figure B.15 shows the magnitude of the 1.75 μs echo relative to the main path, 9.2 seconds into the capture. Notice that the main path amplitude is constant, whereas the echo has variable amplitude due to the Doppler phase rotation. The cycle time for this echo, at this time, is around 6.5 ms, which gives a Doppler frequency of about 150 Hz. The echo magnitude is about -25 dB to -20 dB relative to the main path.

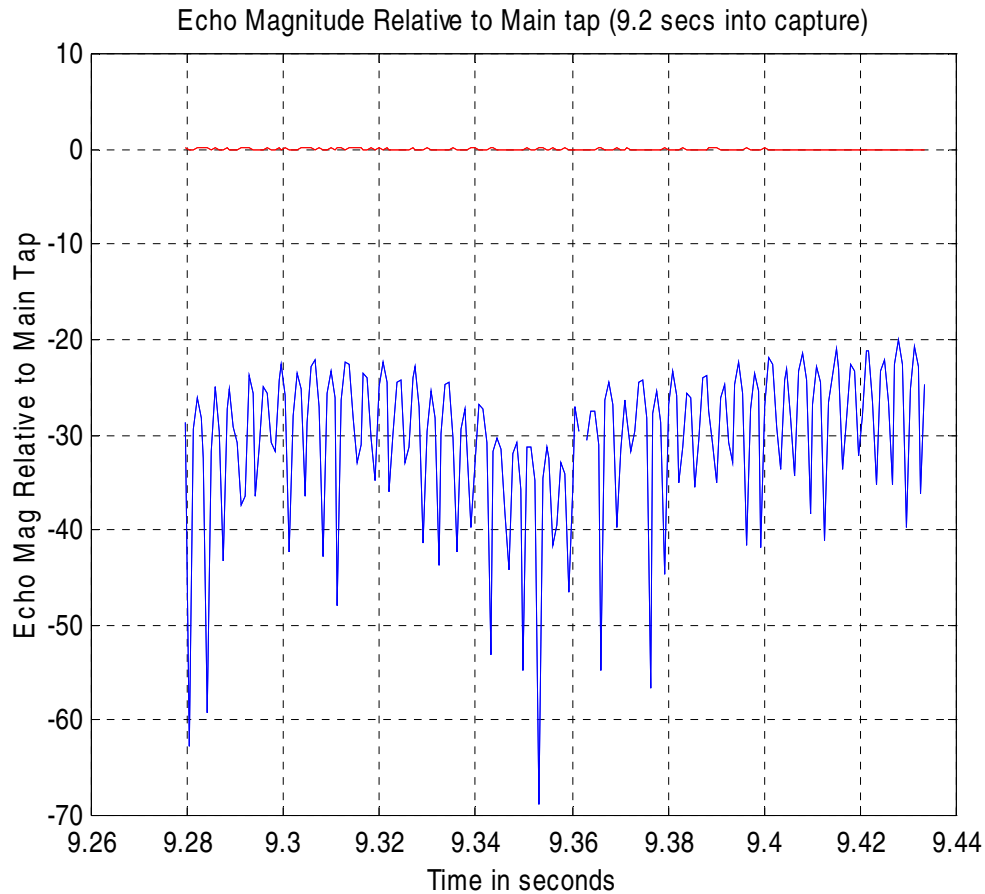

Figure B.15 Echo Magnitude for the 1.75 μs echo relative to the main path, 9.2 seconds into the capture at indoor site WAS-49/36/01. The echo magnitude is -25 dB to -20 dB relative to the main path and has a Doppler frequency of 150 Hz.

Taking another intermediate look at capture WAS-49/36/01, we can see a bobbing channel appear. Figures B.16, B.17, and B.18, occurring at 5.167, 5.227, and 5.279 seconds into the capture, depict the main path and the post-echo exchanging positions. This confirms the plot furnished in Figure B.11.

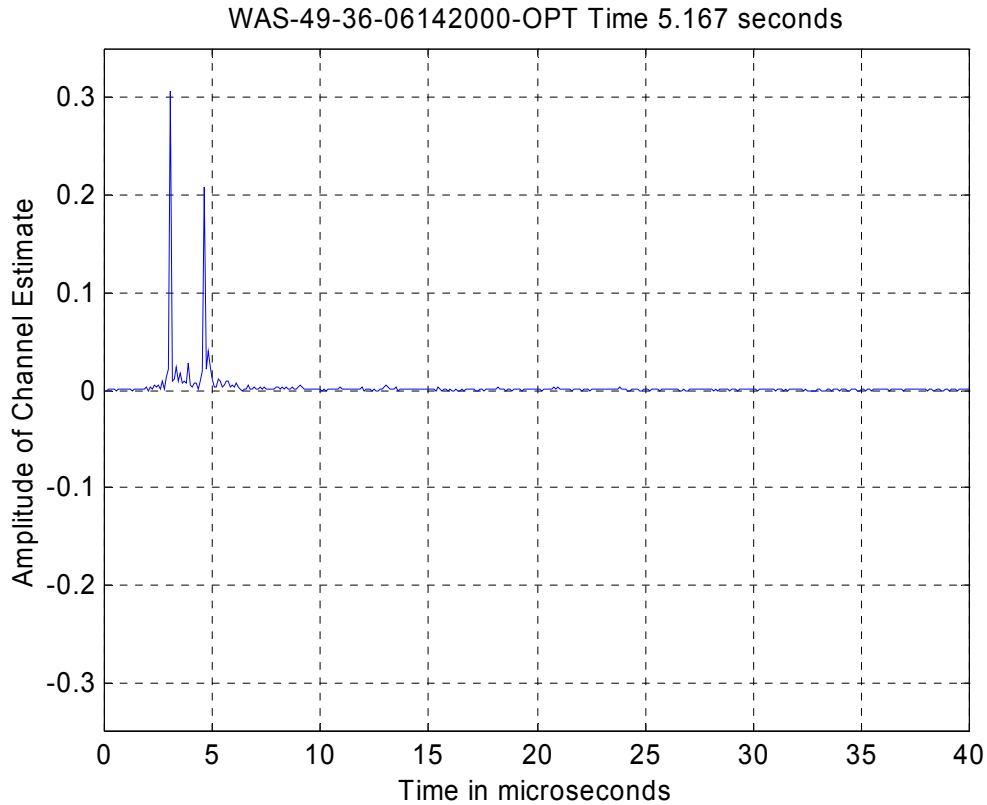

Figure B.16 Channel estimate (absolute value) for the RF capture at indoor site WAS-49/36/01, showing the main path and 1.75 μ s echo.

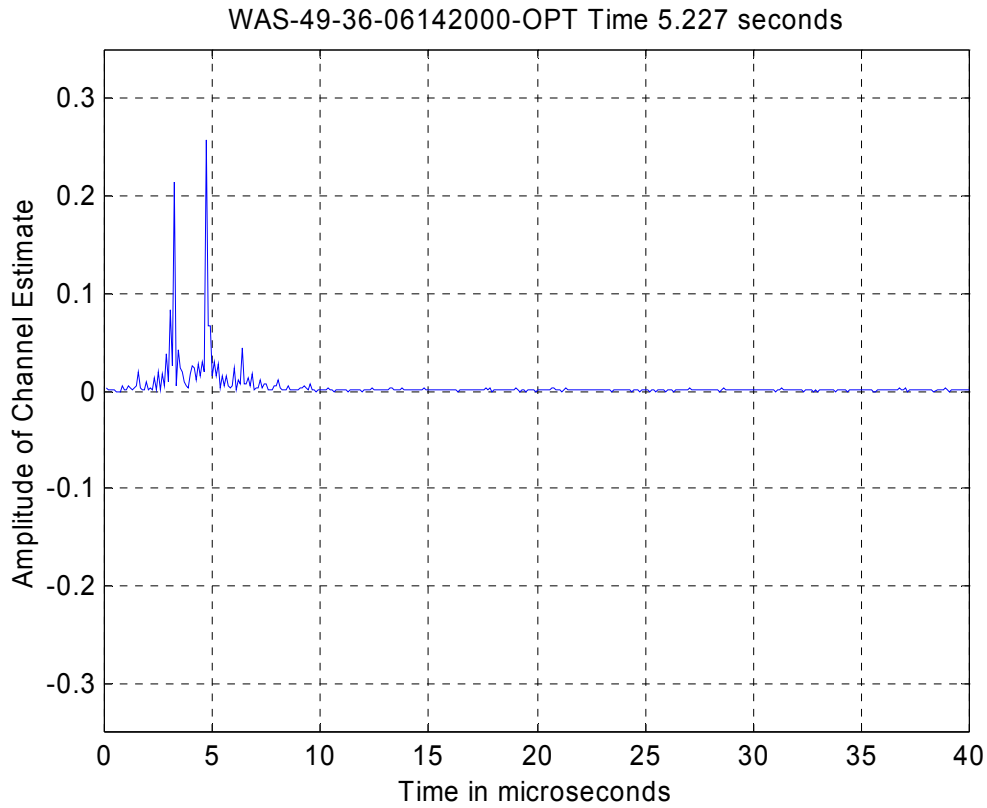

Figure B.17 Channel estimate (absolute value) for the RF capture at indoor site WAS-49/36/01, showing the main path and 1.75 μs echo. The 1.75 μs echo has increased in magnitude with respect to the main path.

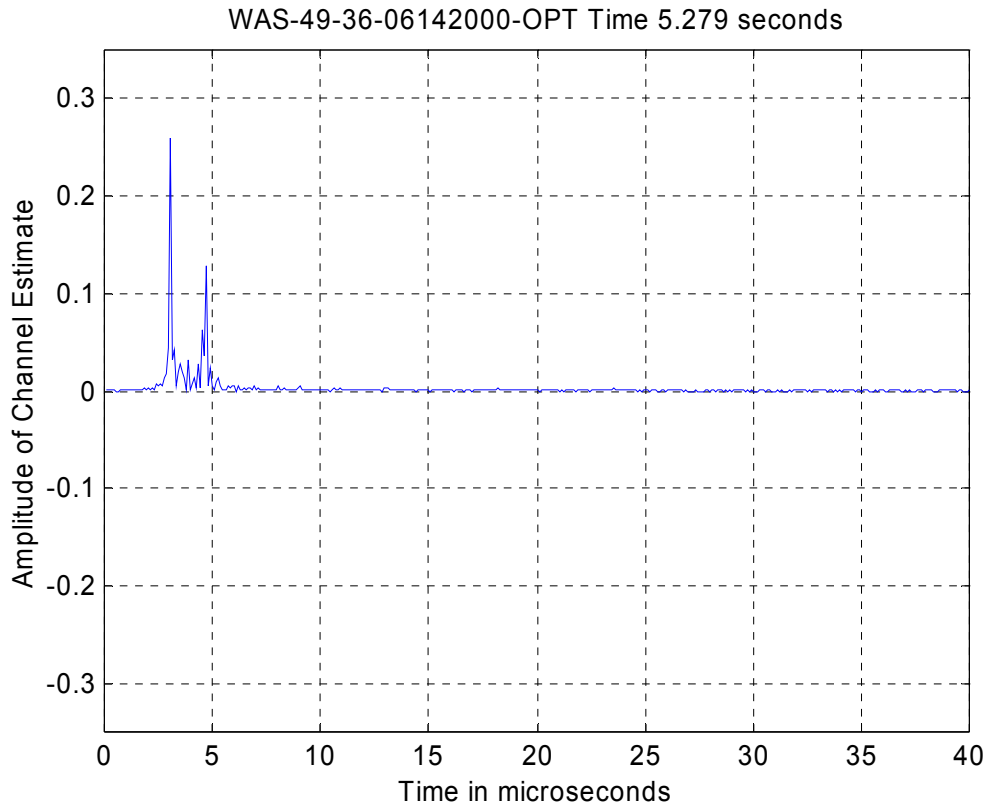

Figure B.18 Channel estimate (absolute value) for the RF capture at indoor site WAS-49/36/01, showing the main path and 1.75 μ s echo. The 1.75 μ s echo is now a post echo with respect to the main path.

3.4 Captured Channel WAS-034/48/01

Figure B.19 illustrates the peak echo power relative to the main power throughout a 25-second RF capture for the indoor capture WAS-34/48/01. The capture has a dynamic main path as well as strong dynamic pre-echoes at $-1.95 \mu\text{s}$ and $-3.07 \mu\text{s}$ and a post-echo at $+15.6 \mu\text{s}$. Site WAS-034/48/01 is a town house located 9.6 miles from the transmitter.

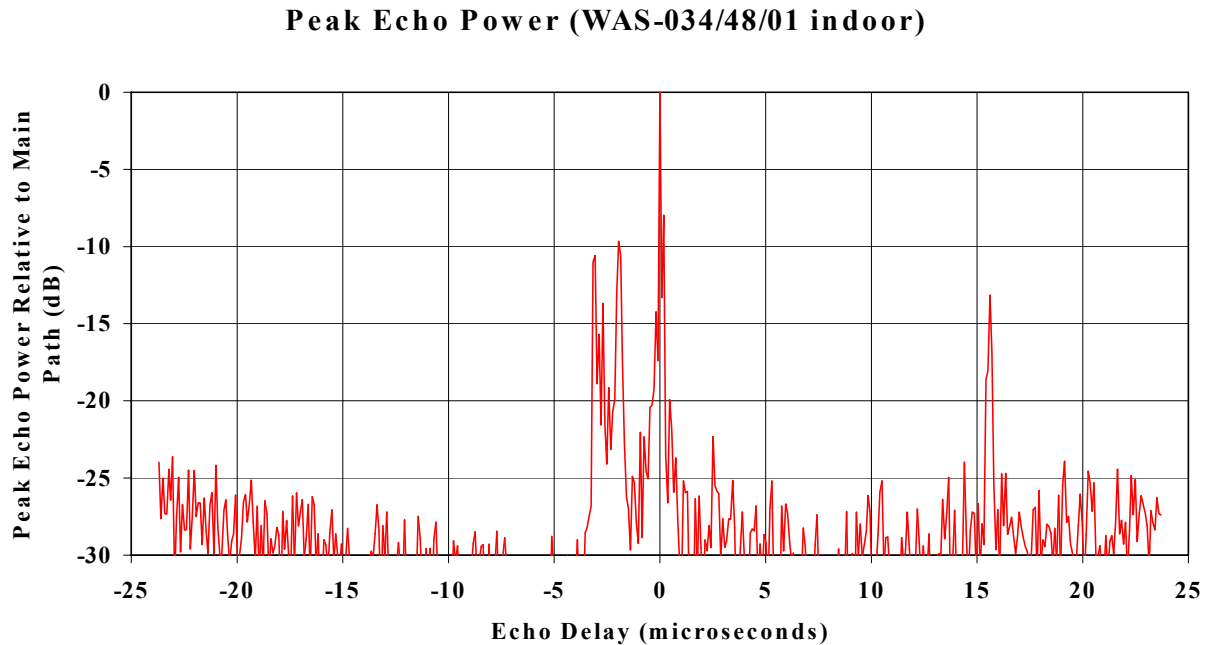

Figure B.19 Peak echo power as a function of echo delay observed for the duration of the RF capture at indoor site WAS-034/48/01.

It is instructive to note that, by observing the channel estimates of WAS-034/48/01 and WAS-034/36/01, it appears that the post-echo in the channel 36 capture is the main path in the channel 48 capture, and the main path in the channel 36 capture is the pre-echo in the channel 48 capture. That is, the echo and the main path have exchanged positions. The echo amplitudes are relatively constant over time in each capture, however, and can therefore be characterized as static. Both channels have a weak echo at $18.5 \mu\text{s}$.

Figure B.20 illustrates the echo power over the 25-second capture. Notice the presence of a slow Doppler affecting the three main paths.

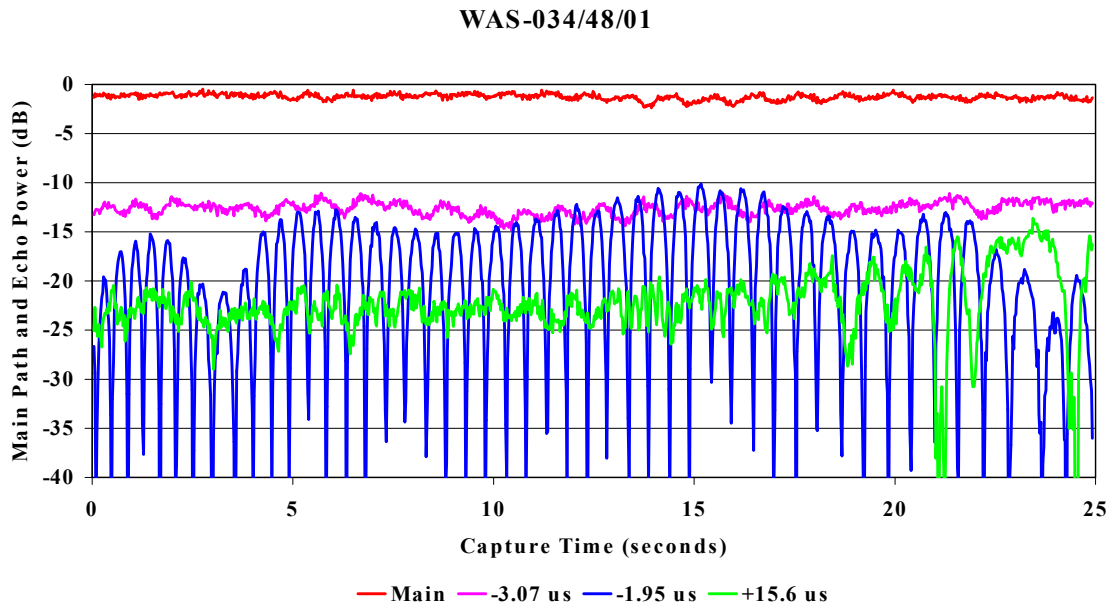

Figure B.20 Power of the main path and three main echoes illustrates the dynamic nature of echoes for indoor site WAS-034/48/01.

3.5 Captured Channel WAS-311/48/01

Another example of a “bobbing” channel is provided with the outdoor capture WAS-311/48/01. This outdoor field capture involved no direct transmission path, even though the receive antenna was only 3.9 miles from the transmit antenna. Figure B.21 illustrates the maximum main path power and echo power observed at any given instance within the capture. The evenly spaced, close-in echoes, peaked at ± 372 ns, indicate that the “main” and “echo” paths alternate.

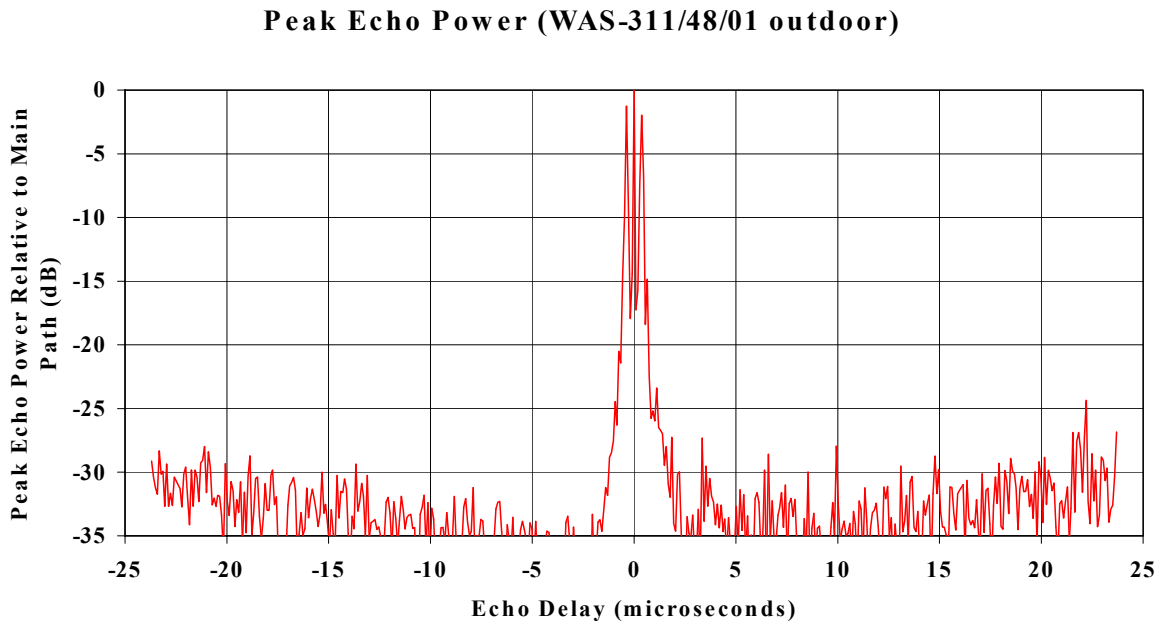

Figure B.21 Peak echo power as a function of echo delay observed for the duration of the RF capture at outdoor site WAS-311/48/01. The evenly spaced close-in echoes peaked at ± 372 ns indicate that the main path and the echo alternate—a “bobbing” channel.

The “bobbing” nature of the echoes is evident in Figures B.22 and B.23. At 22.906 seconds into the capture, a strong 372 ns pre-echo is present, as illustrated in Figure B.22.

Echo Power at 22.906s (WAS-311/48/01 outdoor)

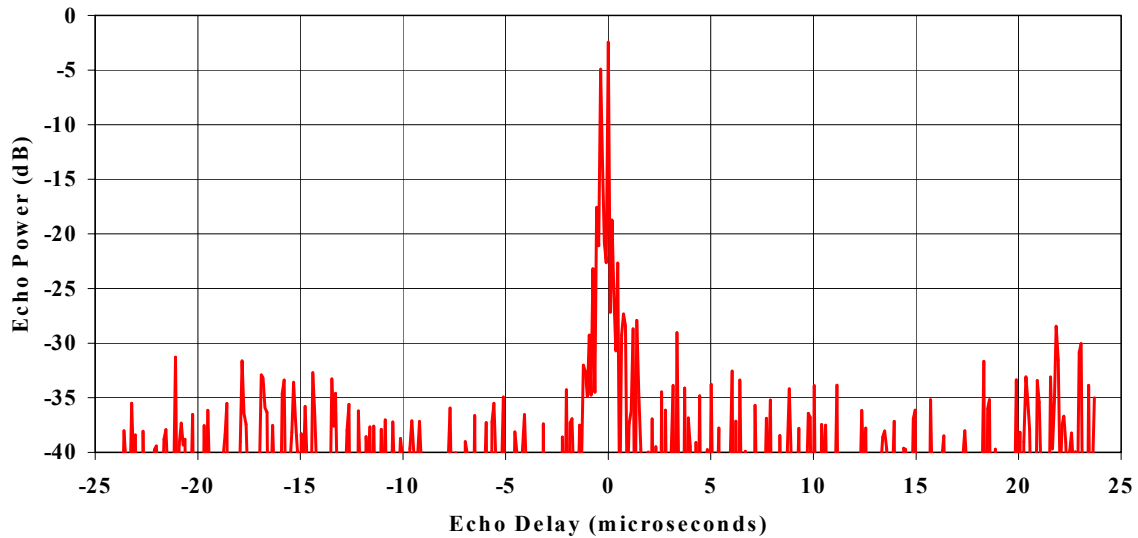

Figure B.22 Echo power as a function of echo delay observed at 22.906 seconds into the RF capture of outdoor site WAS-311/48/01. A strong pre-echo is present at -372 ns.

Two field syncs later in time (at 22.955 seconds), the formerly pre-echo path now exceeds the main path, as illustrated in Figure B.23. The original echo has become the dominant path. It is clear that signal conditions do exist where, although the receive antenna is directional and 30 feet high, strong echoes can be present and may even exceed the dominant path in signal level.

Echo Power at 22.955 sec (WAS-311/48/01 outdoor)

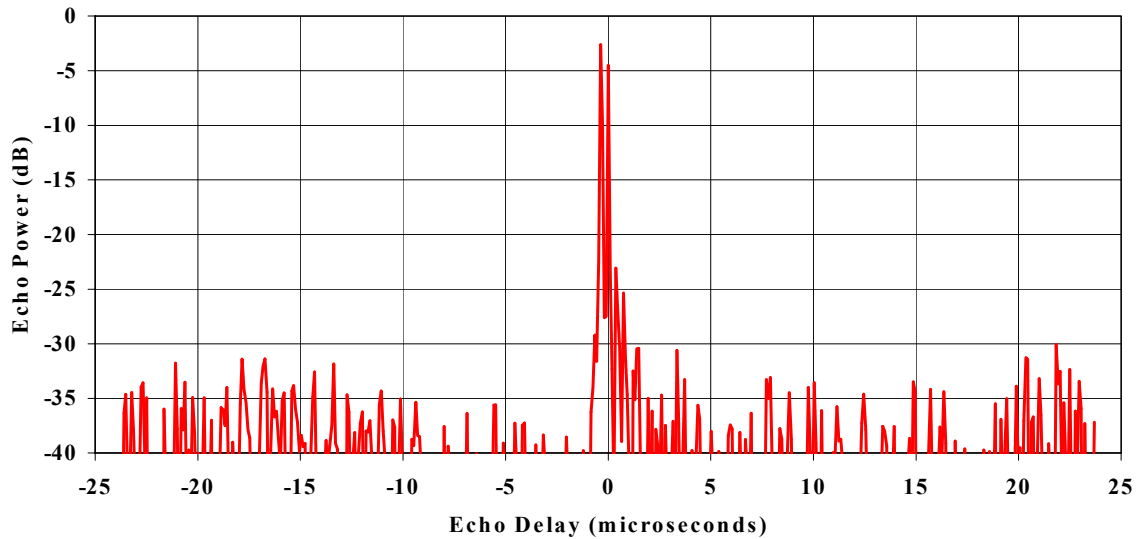

Figure B.23 Echo power as a function of echo delay observed at 22.955 seconds into the RF capture of outdoor site WAS-311/48/01. After two additional field syncs in time, the 372 ns pre-echo is now the dominant path.

3.6 Captured Channel WAS-114/27/01

Figure B.24 illustrates the peak echo power of RF outdoor capture WAS-114/27/01. The figure demonstrates the presence of strong pre- and post-echoes that are close in delay to the main path.

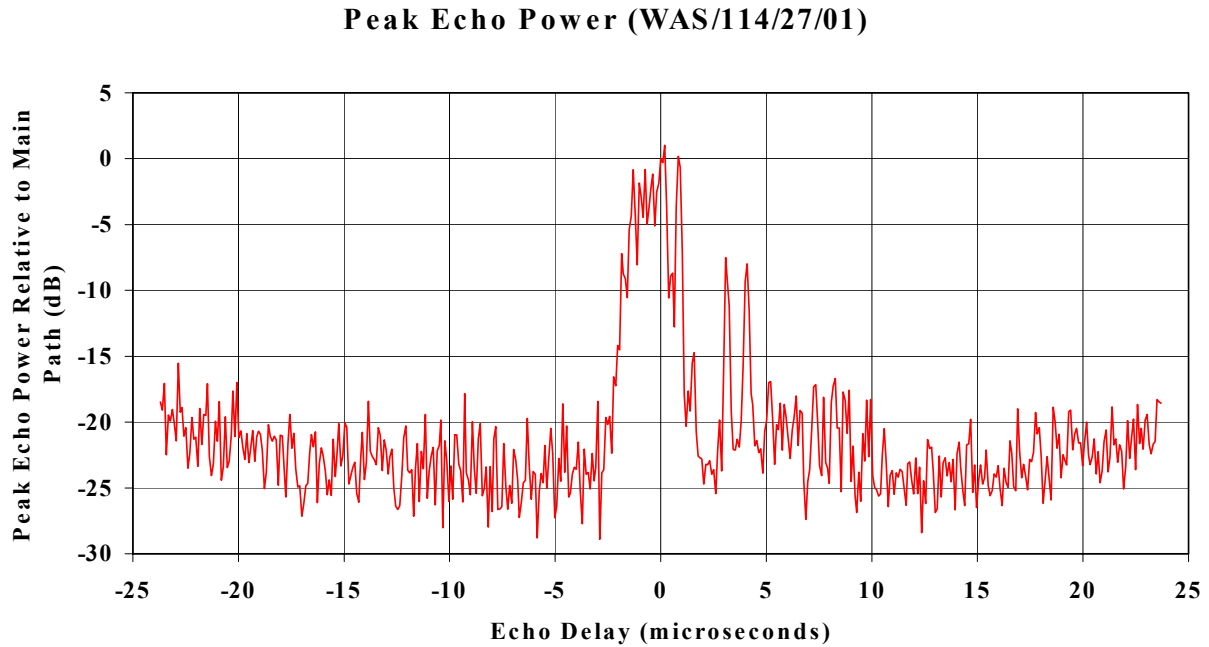

Figure B.24 Peak echo power observed in RF capture WAS/114/27/01

Captured Channel WAS-101/39/01

Figure B.25 illustrates the peak echo power of RF outdoor capture WAS-101/39/01. This channel has a pattern characteristic of a close-in “bobbing channel”.

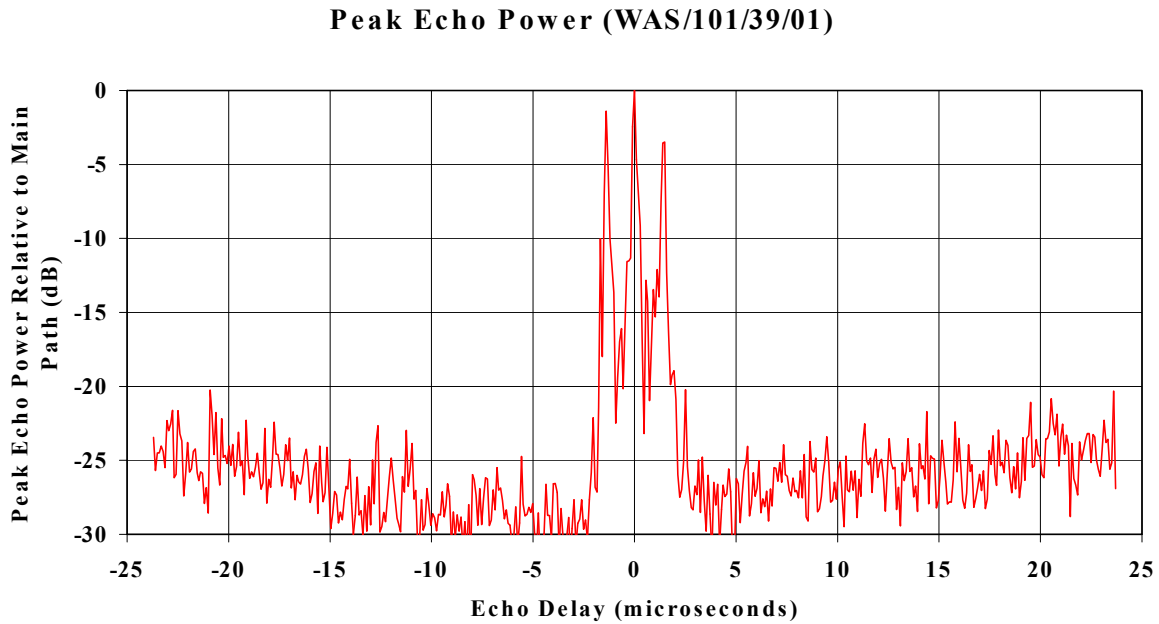

Figure B.25 Peak echo power observed in RF capture WAS/101/39/01

3.7 Captured Channel NYC-216/56/01

Figure B.26 shows the peak echo power of indoor channel NYC/216/56/01 captured with a loop-type antenna six feet above floor level. The figure demonstrates the presence of both strong pre- and post-echoes. The capture location was a fourth-floor urban apartment constructed of wood with brick siding. The room had windows on two adjacent walls.

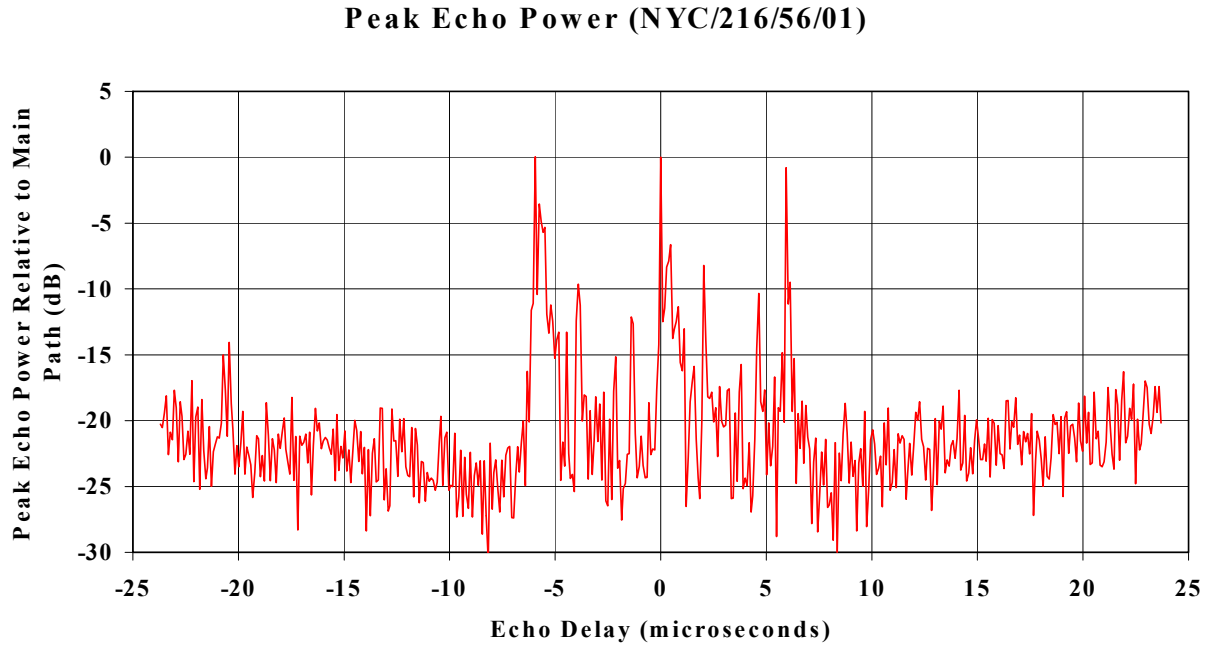

Figure B.26 Peak echo power observed in RF capture NYC/216/56/01 using a loop-type antenna in a fourth-floor urban apartment.

3.8 Captured Channel NYC-217/56/01

Figure B.27 shows the peak echo power of indoor channel NYC/217/56/01 captured at the same location as NYC/216/56/01, using a bowtie-type antenna at a 6-foot height above floor level.

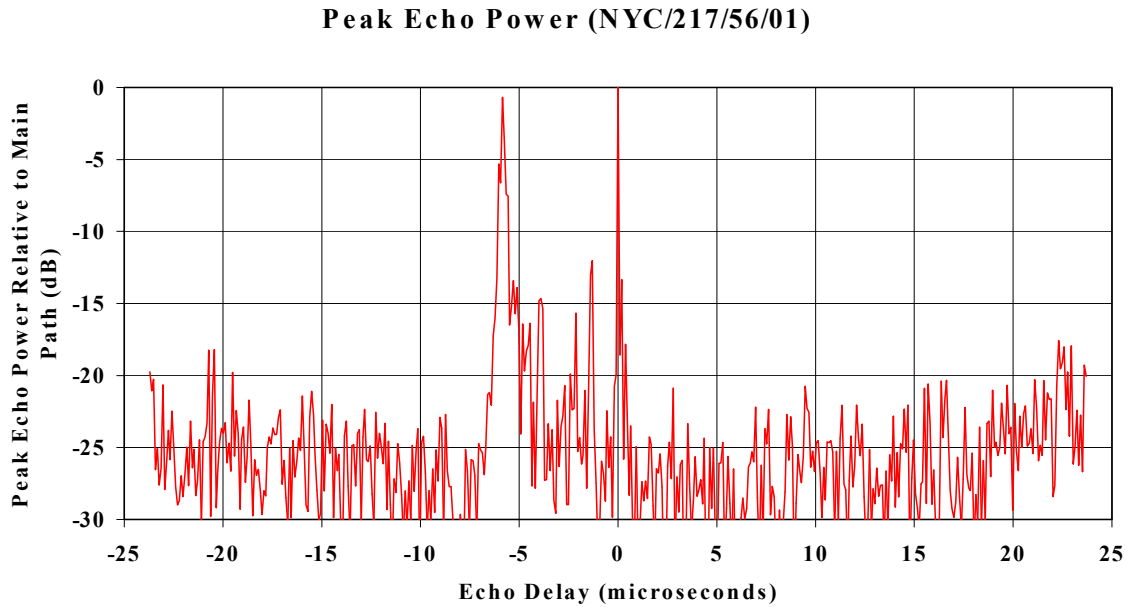

Figure B.27 Peak echo power observed in RF capture NYC/217/56/01 using a single bowtie-type antenna in a fourth-floor urban apartment.

Annex C: Example of Channel Impulse Response with Long Pre and Post-Echo

1. SCOPE

Examples of captured channels with long pre and post echoes are shown below as an illustration of field conditions with possible long RF delay spread.¹⁵

1.1 Far Pre-Echo¹⁶

The channel in Figure C.1 represents the amplitude of the impulse response estimate of a channel capture in the Portland, OR area. The impulse response estimate shows the presence of a pre-echo at approximately $-14 \mu\text{s}$ with a relative amplitude to the main signal of about -10 dB .

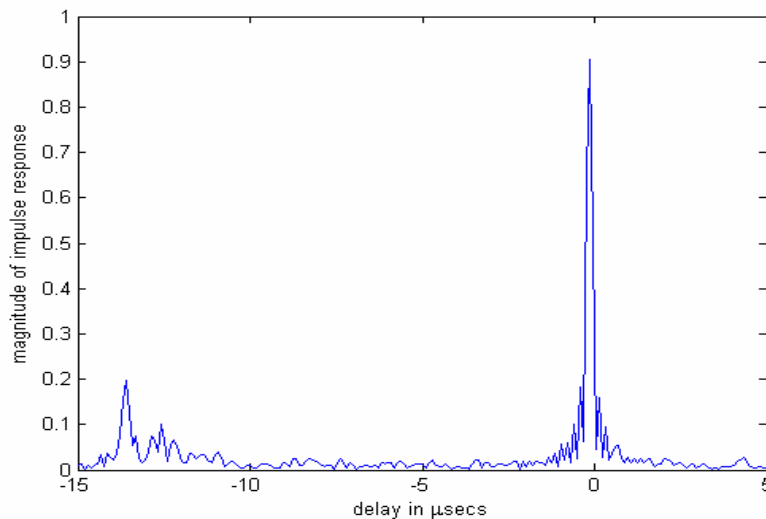

Figure C.1 Channel impulse response with pre echo at $-14 \mu\text{s}$.

¹⁵ It should be noted that the estimates of channel impulse responses in these examples were obtained without use of the PN511 sequence embedded in the field sync data segment (see A/53C [3]).

¹⁶ Although interesting from the multipath point of view, this channel has not been included in the recommended set of field ensembles, as it has been determined that the channel may be affected by capture equipment artifacts.

1.2 Far Post-Echo

The channel in Figure C.2 below represents the amplitude of the impulse response estimate of a channel captured on the roof of a 3-story building in the Philadelphia, PA area. The impulse response estimate shows the presence of a post-echo at approximately $+57 \mu\text{s}$ with a relative amplitude to the main signal of about -19 dB .

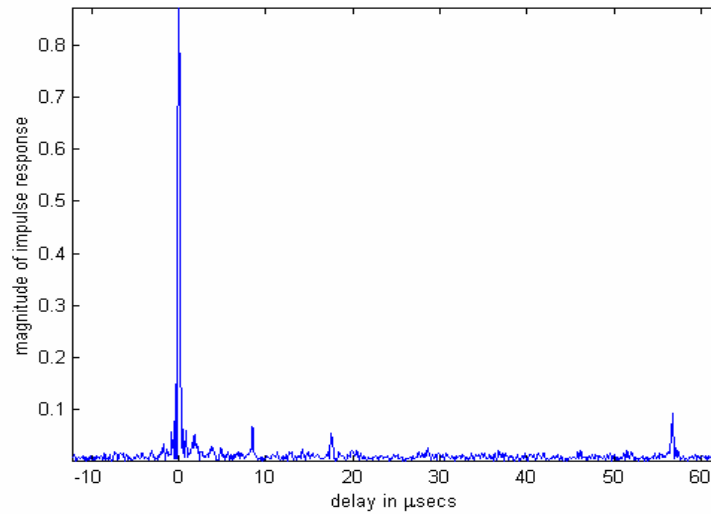

Figure C.2 Channel impulse response with post echo at $57 \mu\text{s}$

Annex D: Analysis of Received Power for a Sample Receiver

The calculations in Annex D are an analysis of the received power for a sample receiver located in Hollywood, Fla., 33021. The receiving antenna was assumed to be the FCC standard antenna with a 10 dBd (12 dBi) gain and a 14 dB front to back ratio. The receiver line loss was assumed to be 4 dB. There was no consideration of balun loss, mismatch loss, etc. The receiving antenna was assumed to be pointed to the WBZL-DT transmitting facility.

All nearby transmitting facilities were identified that would have significant signals at the Hollywood location. The transmitting facilities' azimuth and elevation patterns were employed to estimate the received signal level. The FCC standard receiving antenna azimuth pattern was employed. There was no consideration of receiving antenna elevation pattern effects, which were assumed to be negligible for the location under study.

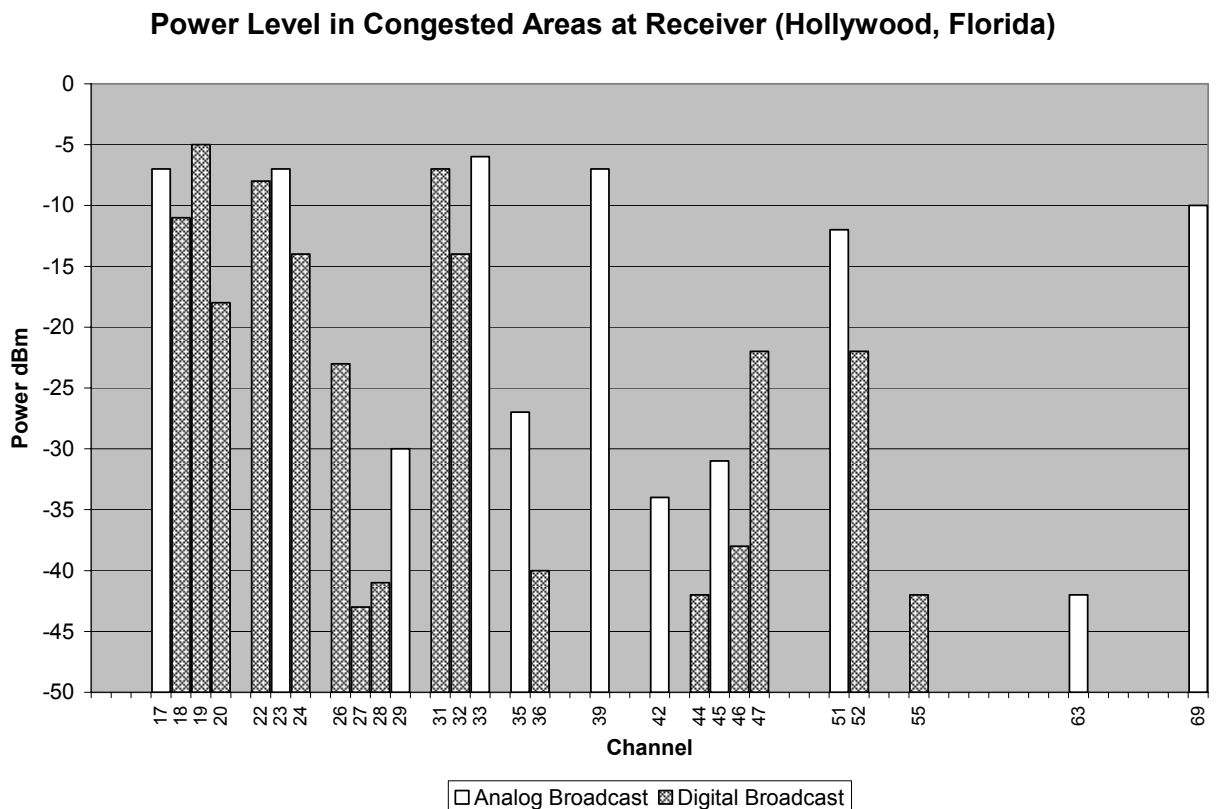

Figure D.1 Power level at specified receiver.

Table D.1 TV/DTV Received Power Analysis; Location: Hollywood, Fla.

TV Channel	Station Call Sign	Mode	Distance (km)	Compass Direction from Receiver (deg.)	Maximum ERP (kW)	Antenna Height Above MSL (m)	Calculated RF Power at Receiver (dBm)
17	WLRN-TV	Analog	6.8	193	2820	311	-7
18	WPBT-DT	Digital	6.8	193	1000	311	-11
19	WBZL-DT	Digital	6.1	204	1000	254	-5
20	WLRN-TV	Digital	4.3	179	625	303	-18
22	WFOR-TV	Digital	6.1	204	1000	300	-8
23	WLTV(TV)	Analog	6.1	204	4470	299	-7
24	WLTV-DT	Digital	6.1	204	500	259	-14
26	WPXM-DT	Digital	3.7	174	200	284	-23
27	WXEL-DT	Digital	62	356	400	444	-43
28	WFLX-DT	Digital	62	356	630	462	-41
29	WFLX(TV)	Analog	62	356	5000	462	-30
31	WTVJ-DT	Digital	6.1	204	1000	314	-7
32	WBFS-DT	Digital	5.8	192	1000	263	-14
33	WBFS-TV	Analog	5.8	192	5000	286	-6
35	WPXM(TV)	Analog	38.8	198	3420	103	-27
36	WPXP-DT	Digital	63.2	359	1000	390	-40
39	WBZL(TV)	Analog	6.1	204	5000	278	-7
42	WXEL(TV)	Analog	52	356	2140	444	-34
44	WPPB-DT	Digital	3.7	141	565	311	-42